

# Development of *SANMOTION C Wireless Adapter 3A*

Shigeki Sato Tomonobu Tazaki Hiroto Endo

Naoto Miura Masayuki Mizutani Ryunosuke Murakami

## 1. Introduction

In the manufacturing industry, production equipment that uses wireless communication technology has been developed to improve production efficiency and facilitate timely responses to customer needs and market changes. As one example, notifications of production equipment abnormalities can be sent remotely through wireless communication so that problems can be quickly resolved. As such, production equipment is required to support such functionality to effectively use wireless communication for improved maintainability. In addition, there is also demand for add-on products that can easily add wireless communication features to make existing production equipment IoT-ready.

To meet this demand, we developed the *Wireless Adapter 3A* as an add-on product that can provide the *SANMOTION C S100* motion controller (hereinafter, *S100*) with wireless capabilities. The “3A” in the product name stands for: Anytime (can check information whenever it is needed), Anywhere (can be used no matter in which country it is installed), and Anything (can connect to a PC or smart device).

This article will introduce the features of this new product.

## 2. Product Overview

### 2.1 Appearance and dimensions

Figure 1 shows the appearance of the *Wireless Adapter 3A* and Figure 2 shows its dimensional drawing.

The new product comes with a USB interface and can be used by connecting it to the USB connector on the front of the *S100*. When mounted to the *S100*, it fits within the cable wiring space so as not to interfere with other equipment (see Figure 3). In addition, the adapter has an easy-to-grasp grip on its side to prevent it from slipping. This design makes it easy to be connected to and disconnected from the *S100* (see Figure 4).



Fig. 1 *Wireless Adapter 3A*

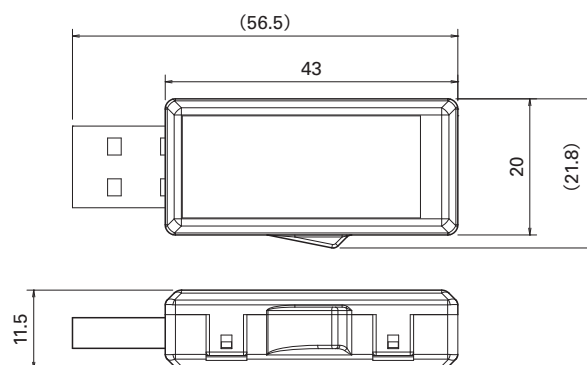

Fig. 2 Dimensional drawing of *Wireless Adapter 3A* (Unit: mm)

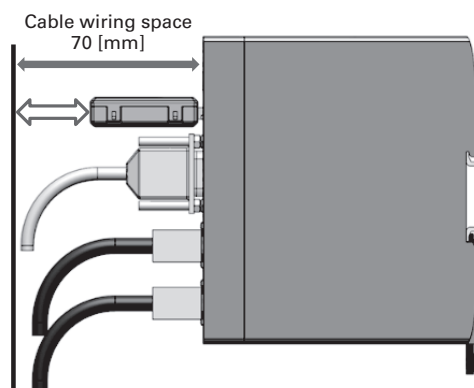

Fig. 3 Illustration of spacing when mounted to the *S100*

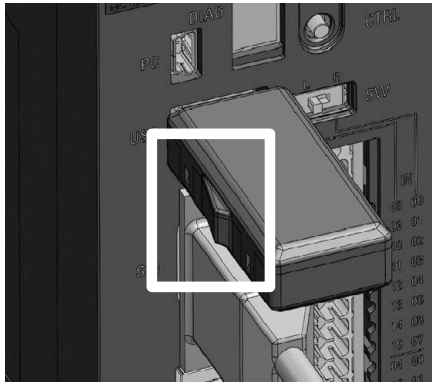

Fig. 4 Side grip

Table 1 shows the basic specifications of the *Wireless Adapter 3A*.

Table 1 Basic specifications

<b>Interface</b>	USB 2.0 Type A
<b>Wireless standard</b>	Compliant with IEEE 802.11 b/g/n
<b>Frequency band</b>	2.4 GHz
<b>Data rate</b>	IEEE 802.11b: Up to 11 Mbps IEEE 802.11g: Up to 54 Mbps IEEE 802.11n: Up to 72.2 Mbps
<b>Maximum number of connectable units</b>	3
<b>Operation mode</b>	Access point mode Station mode
<b>Security</b>	WPA2-PSK (AES)
<b>Operating temperature</b>	0 to +55°C
<b>Storage temperature</b>	-40 to +70°C
<b>Humidity</b>	10 to 95% (non-condensing)
<b>Dimensions (W×H×D)</b>	21.8 × 11.5 × 56.5 mm
<b>Mass</b>	Approx. 10 g
<b>Wireless standard</b>	TELEC (Japan) FCC (USA) ISED (Canada) CE (Europe) SRRC (China) NCC (Taiwan) NBTC (Thailand)

### 3. Features

#### 3.1 Helps build wireless networks easily

Wireless features can be used by simply connecting the new product to the USB interface of the *SI100*. Wireless settings can be configured using the *SANMOTION C Software Tool*, an integrated development tool (see Figure 5). It does not require any advanced knowledge of networks and its setting parameters have been kept to a minimum.

The new product has two operation modes: an access point mode (acting as a master network station) and a station mode (acting as a slave network station). In the access point mode, wireless devices can be easily connected to each other even in environments without wireless networks. When a wireless network is available, in the station mode, the product can be used as a slave network station.

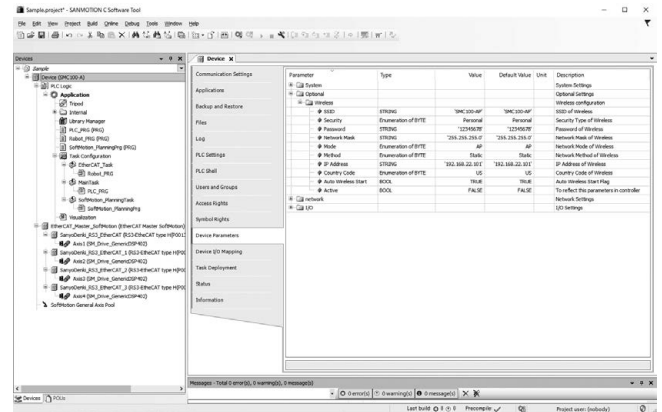

Fig. 5 Wireless LAN setting screen

#### 3.2 Complies with IEEE 802.11b/g/n (2.4 GHz) wireless standards

Table 2 shows major wireless standards. The new product uses the IEEE 802.11b/g/n wireless standards that provide fast and long-distance communication, and supports the 2.4 GHz frequency band that provides greater penetration through obstructions such as walls.

The 2.4 GHz band is susceptible to inter-channel interference because it is used by a large number of devices. However, the new product comes with a function for checking ambient signal conditions. It automatically selects the best channel based on signal conditions, providing stable communications.

#### 3.3 Compliant with radio laws of many countries

When exporting production equipment that comes equipped with wireless devices, it is necessary to meet the requirements of the radio communication regulations of importing countries. This means that the wireless devices of the production equipment would need to be replaced with devices compatible with the regulations of the importing country. However, the new product doesn't have to be replaced. By simply reconfiguring the setting parameters, it can be made compliant with the laws of many countries, including Japan, the United States, Canada, countries in Europe, China, Taiwan, and Thailand.

Table 2 Wireless standards

Items	Frequency [MHz]	Communication speed [Mbps]	Communication range [m]	Number of connectable units [Qty]	Radio wave interference	Power consumption	Versatility
Wireless LAN IEEE 802.11n	2400	65 to 300	100	32	Poor	Poor	Good
Bluetooth	2400	1 to 24	20	7	Average	Average	Average
ZigBee	2400 920	0.02 to 0.25	50	65,536	Good	Good	Poor

### 3.4 Shortens production facility downtime

By combining the new product with the web-based data visualization function of the S100, operators can view the status of production equipment in real time using smart devices (see Figure 6). In the event of an abnormality, operators are instantly notified of the circumstances so that they can quickly investigate the cause and perform recovery work. This minimizes equipment downtime.



Fig. 6 Visualization of production equipment conditions

In addition, it is often the case in manufacturing sites that communication of information between devices is performed using wired connections. Therefore, changing the layout of a manufacturing line will require time-consuming wiring work. In the event that a cable is damaged during wiring, this could result in a significant amount of manufacturing downtime. By using the new product to make communication wireless, wiring work becomes unnecessary and the layout of manufacturing lines can be flexibly changed with no risk of damaging cables (see Figure 7).

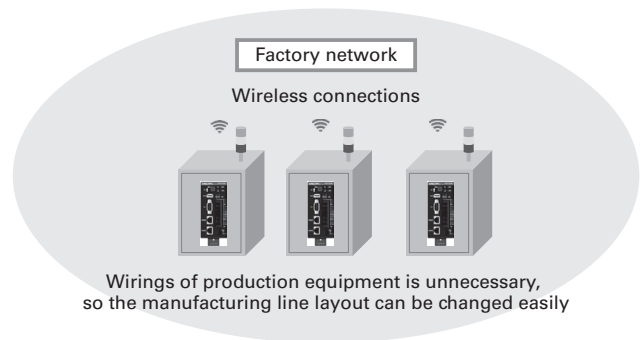

Fig. 7 Easy layout change

### 3.5 Improved maintainability

Figure 8 compares wired and wireless environments. Production equipment may sometimes be installed in locations where maintenance is difficult or even dangerous. The new product is especially useful in these environments. It enables operators to remotely diagnose failures in production equipment, perform program maintenance, configure servo systems, and update firmware from a safe location, greatly improving maintainability.

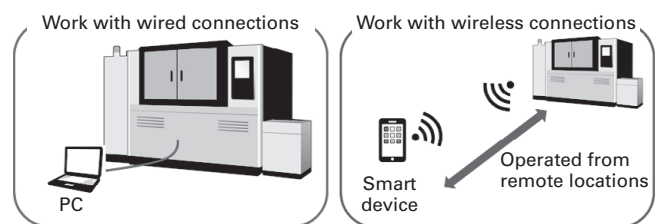

Fig. 8 Comparison of maintenance

## 4. Conclusion

---

This article introduced the features of the *Wireless Adapter 3A*. To recap, it can do the following:

- (1) It can connect to the USB interface of the *S100* to provide the *S100* with wireless capabilities that simplify the construction of a wireless environment.
- (2) It complies with the radio communication regulations of various countries, and doesn't have to be replaced when imported.
- (3) It provides wireless capabilities that shorten production equipment downtime and improve maintainability.

The new product makes it easy to add wireless capabilities to the *SANMOTION C S100* motion controller. We expect that it will improve maintainability and contribute to the easy construction of manufacturing lines. We will continue to develop products that meet market needs and help create new value for our customers' manufacturing.

Author

### **Shigeki Sato**

Servo Systems Div., Design Dept. 2  
Works on the design and development of Servo Systems products.

### **Tomonobu Tazaki**

Servo Systems Div., Design Dept. 2  
Works on the design and development of Servo Systems products.

### **Hiroto Endo**

Servo Systems Div., Design Dept. 2  
Works on the design and development of Servo Systems products.

### **Naoto Miura**

Servo Systems Div., Design Dept. 2  
Works on the design and development of Servo Systems products.

### **Masayuki Mizutani**

Servo Systems Div., Design Dept. 2  
Works on the design and development of Servo Systems products.

### **Ryunosuke Murakami**

Servo Systems Div., Design Dept. 2  
Works on the design and development of Servo Systems products.