



# Development of the Small Capacity UPS “SANUPS A11H”

Hiroyuki Hanaoka  
Hidenori Takizawa

Narumi Yanagisawa  
Hirofumi Kimura

Hiroshi Sakaba

Masahiko Nagai

## 1. Introduction

In recent years, as information communication technology (IT) has expanded globally, various IT systems have been introduced. In this situation, two extremely important factors when considering public use of a system are reliability and stable operation or maintenance for devices that are connected to servers, routers, and other network systems. This reliability is also required in the power source that supplies power to the device. Uninterruptible power supplies (referred to below as UPS) are a large part in this reliability.

There are many cases where companies cannot keep up with improvements to the power supply and infrastructure, and despite the unstable power, investments to IT systems are given higher priority. Therefore, UPS are often used to stabilize power for the user. However, there are obviously still many cases where power fluctuations appear, which increases the use of backup operations from the batteries. In extreme situations, not only can appropriate backup time be unavailable, but the battery life is shortened.

This UPS was developed to provide reliable power even during an unstable environment. This document introduces an overview of the product.

## 2. Background of the Development

In the past, UPS were developed with providing a stable supply of power as the most important function, but as noted previously, there is increasing interest in devices that can handle large fluctuations in power supply. The “SANUPS A11H” was developed to meet these requests and provide further stability for power supply.

## 3. Features

Currently, development has been completed for the following models in the “SANUPS A11H” Series: 1 kVA tower type and rack type, and the 1.5 kVA, 2 kVA, and 3 kVA rack type.

Fig. 1 shows a photograph of the “SANUPS A11H” 1 kVA tower type.



Fig. 1 “SANUPS A11H” 1 kVA tower type

The features of this product are as follows.

### 3.1 Wide range input

The biggest feature of the “SANUPS A11H” is the wide range input. The input voltage and frequency ranges that can be used for commercial operations with this UPS were widened as much as possible, eventually achieving a voltage range of 55 V to 150 V and a frequency range of 40 Hz to 120 Hz. The conventional UPS was a device rated for 120 V, 60 Hz, with a voltage range of 102 V to 138 V and a frequency range of 54 Hz to 66 Hz. As you can see, the range for the A11H Series is considerably larger. This provides the following advantages.

- (1) Even if the input voltage is unstable and there are large fluctuations, stable power can be supplied.
- (2) The device is less likely to switch to battery operations, so this reduces risks such as insufficient battery power or shortened battery life.

### 3.2 Continuous inverter power supply system UPS

The "continuous inverter power supply system" is used to provide stable power supply.

### 3.3 Support for engine generators

By using the features noted previously in sections 3.1 and 3.2, stable power can be supplied to the load even when UPS input is connected to an engine generator. Even under conditions that would cause the conventional UPS to switch to battery operation momentarily, such as when both the voltage and frequency on the engine generator fluctuate wildly the instant that the load is thrown in, this new UPS can continue operating with AC input.

### 3.4 Automatic battery checking

This UPS contains a function that automatically checks the battery at regular intervals. There are many instances where backup cannot be performed during a power failure due to power deterioration. This function notifies the user ahead of time about battery deterioration over time so that these problems can be reduced. The cycle for battery checking can be set to "None" or 1, 3, or 6 months. (The factory default setting is 6 months).

### 3.5 UPS management software

This UPS includes RS-232C as a standard feature and comes with the UPS management software "SANUPS SOFTWARE STANDALONE". Use the included connection cables to connect to the computer or server. As shown in Fig. 2, the operation status of the UPS can be identified at a glance on the graphical display screen. This software also includes functions for measurement, shutdown, and scheduled operations.

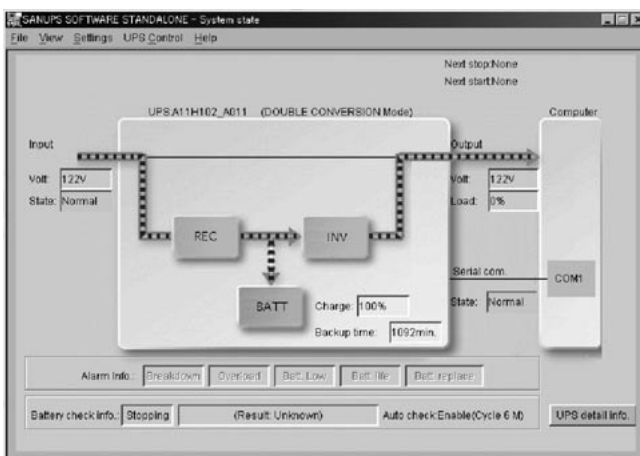

Fig. 2 UPS management software "SANUPS SOFTWARE STANDALONE" screen

### 3.6 Ease of battery replacement

In the UPS, the battery is incorporated into a resin tray as a pack, so the structure allows the battery to be easily removed. Therefore, the system is hot-swappable and the battery can be replaced without stopping the device. Fig. 3 shows an image of replacing the battery in the 1 kVA tower type.

Furthermore, the battery pack is the same as the one used for the conventional product, which simplifies maintenance management.

The service parts used for the battery have a five year life. Combined with the effects of the widened range, the maintenance costs for processes such as battery replacement can be reduced.

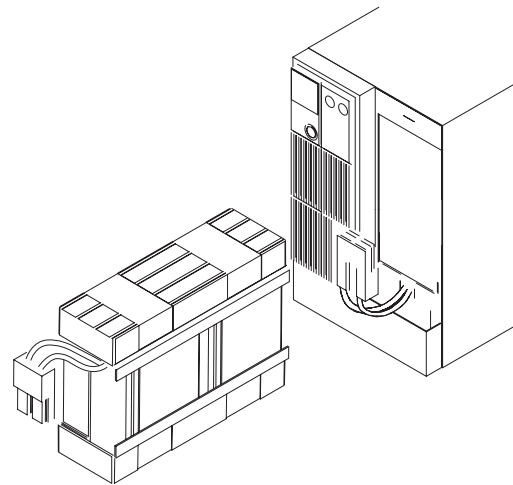

Fig. 3 Battery replacement

### 3.7 Rack mountable

In addition to mounting in the 19-inch rack, the rack type UPS can be mounted vertically or horizontally in floor or tabletop installations. Rack mount tools are included for rack mounting and a molded stand is included for vertical mounting. Besides the rack type, the tower type is also available.

### 3.8 Reduction of acoustic noise

Reductions to the acoustic noise were introduced by performing controls to adjust the fan's rotating speed according to the UPS heat. When compared to conventional models, acoustic noise reduction of approximately 9 dB at a load factor of 20% and approximately 6 dB at a load factor of 50% was achieved.

### 3.9 Network compatibility

The optional UPS management software "SANUPS SOFTWARE" and a LAN interface card are included in order to perform UPS management in a network environment. By using these options, a flexible and powerful network environment can be constructed.

### 3.10 High performance interface

A high performance interface is mounted on the UPS as a standard feature. By including the high performance interface, linked operations, remote switch, EPO, contact interface, and system control (requires an optional outlet box) can be performed.

The linked operation function uses cables to connect UPS (up to five unit). After setting staggered times for each output, startup or stop operations can be performed with this function. By using this function, inrush current can be prevented when starting up devices at staggered times and allows servers or storage devices to be started up or stopped in order.

### 3.11 Options

The following options are available for this UPS.

- (1) Long discharging time battery
- (2) Output isolation transformer (1 kVA tower type only)
- (3) Long discharging time battery and output isolation transformer (1 kVA tower type only)
- (4) LAN interface card
- (5) Contact interface card
- (6) Outlet box (for system control)

## 4. Circuit architecture

Fig. 4 shows the UPS circuit block diagram.

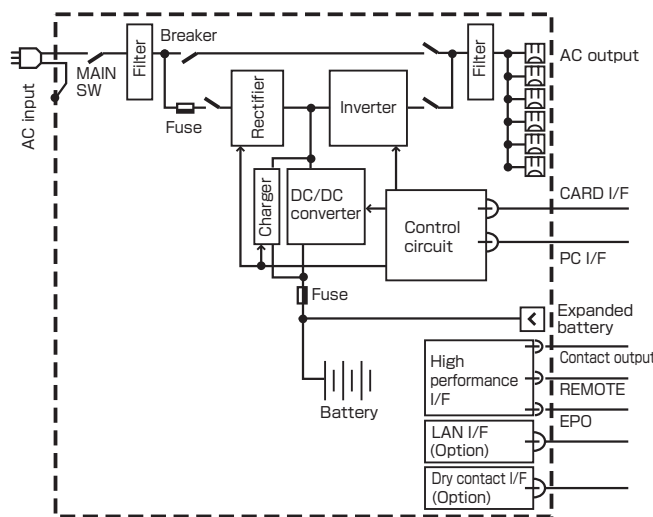

Fig. 4 Circuit block diagram

### 4.1 Main circuit architecture

This UPS consists of a rectifier (high power factor converter), inverter, charger, DC/DC converter, and battery, and it contains the following innovations.

- (1) Half bridge method converters and inverters are used to reduce the number of parts.
- (2) By using a high-frequency transformer for the battery voltage part, the size can be reduced.

### 4.2 Control circuit architecture

Two areas of control, waveform control and sequence control, are consolidated into a single CPU on this UPS to reduce the number of parts. Furthermore, by relegating conventional hardware tasks to software, the hardware can be slimmed down. With these measures, the number of parts has been reduced approximately 34% compared to control circuits in conventional models.

### 4.3 Electrical characteristics

Table 1 shows the general specifications for the UPS.

## 5. Conclusion

As information communication technology becomes more sophisticated, its social importance will continue to grow. Along with this, it is predicted that the number of cases where UPS are used in environments with poor power supplies will also rise. We will continue to quickly develop products to meet these market demands and provide devices that fulfill our customers' needs. We sincerely thank the many people involved in the development and realization of this UPS product for their advice and support.

Table 1 General specifications for "SANUPS A11H"

Item	A11H				Remarks	
	1 kVA rack type 1 kVA tower type	1.5 kVA rack type	2 kVA rack type	3 kVA rack type		
<b>Output capacity</b>	1 kVA / 0.7 kW	1.5 kVA / 1.05 kW	2 kVA / 1.4 kW	3 kVA / 2.1 kW		
<b>Method</b>	<b>Operation method</b>	Continuous inverter power supply system				
	<b>Cooling method</b>	Forced air cooling				
<b>AC input</b>	<b>No. of phases/wires</b>	Single phase, dual wire				
	<b>Voltage</b>	55 V to 150 V*				
	<b>Frequency</b>	40 Hz to 120 Hz				
	<b>Input power factor</b>	0.95 min.			When input voltage distortion is within 1%	
<b>AC output</b>	<b>No. of phases/wires</b>	Single phase, dual wire				
	<b>Rated load power factor</b>	0.7 (delay)			Fluctuation tolerance: 0.7 (delay) to 1.0	
	<b>Rated voltage</b>	120 V			Setting changeable	
	<b>Voltage precision</b>	Within $\pm 2\%$			Depending on the input and load variance range	
	<b>Rate frequency</b>	60 Hz				
	<b>Frequency precision</b>	<b>Synchronized with commercial line</b>	Rated frequency within $\pm 1, 3, 5\%$			Setting changeable (initial value 5%)
		<b>Self-running oscillator</b>	Within $\pm 0.5\%$			
	<b>Voltage wave form distortion factor</b>	<b>Linear load</b>	3% max.			During rated operations
		<b>Wave rectifier load</b>	7% max.			During rated operations/ 100% wave rectifier load
	<b>Transient voltage fluctuation</b>	<b>Sudden variation of input voltage</b>	Within $\pm 5\%$			During switch between power outage and power return, during sudden variation of input voltage
		<b>Sudden variation of load</b>	Within $\pm 5\%$			During sudden variation between 0% and 100%
<b>Overload capacity</b>	<b>Inverter</b>	105% (200 mS)			Depending on rated load power factor	
	<b>Bypass</b>	800% (2 cycles)				
<b>Overcurrent protection</b>	Protective breaker			During bypass operation		
<b>Battery</b>	<b>Type</b>	Miniature sealed lead acid battery				
	<b>Backup time</b>	5 minutes		3.5 minutes	Ambient temperature 25°C, rated output, initial value	
<b>Acoustic noise</b>	40 dB max.		45 dB max.	50 dB max.	1 m from the front of the device, A characteristics	
<b>Heat generation</b>	125 W	185 W	250 W	370 W		
<b>Environment</b>	<b>Ambient temperature</b>	0 to 40°C				
	<b>Relative humidity</b>	20 to 90%			No condensation	
<b>Foreign safety standards</b>	UL1778 4th Edition (E226092) FCC Part15 Subpart B Class A					

\* At 96 V or less, it switches to battery operations after one minute.

The rate of reduction for load is less than 40% at 55-68 V and less than 70% at 68-80 V. If the load factor exceeds these values, then the device quickly switches to battery operation



#### Hiroyuki Hanaoka

Joined Sanyo Denki in 1988.  
Power Systems Division, 2nd Design Dept.  
Worked on the development and design of UPS.

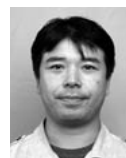

#### Masahiko Nagai

Joined Sanyo Denki in 1993.  
Power Systems Division, 2nd Design Dept.  
Worked on the development and design of UPS.

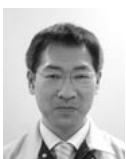

#### Narumi Yanagisawa

Joined Sanyo Denki in 1995.  
Power Systems Division, 2nd Design Dept.  
Worked on the development and design of UPS.



#### Hidenori Takizawa

Joined Sanyo Denki in 1997.  
Power Systems Division, 2nd Design Dept.  
Worked on the structural design of UPS.



#### Hiroshi Sakaba

Joined Sanyo Denki in 1990.  
Power Systems Division, 2nd Design Dept.  
Worked on the development and design of UPS.



#### Hirofumi Kimura

Joined Sanyo Denki in 2007.  
Power Systems Division, 2nd Design Dept.  
Worked on the development and design of UPS.