

# Splash Proof Fan "WS" Series

Michinori Watanabe  
Satoshi Fujimaki  
Naruhiko Kudou

Kesatsugu Watanabe  
Michihiro Suzuki

Minoru Fujiwara  
Takashi Kaise

---

## 1. Introduction

---

Sanyo Denki has developed Splash Proof Fan "W" Series, based on long life fans, as fan motors for cooling outdoor equipment. These fans are used to cool equipment in outdoor applications where ordinary fan motors are hard to use and are vulnerable to rain.

On the other hand, the market needs splash-proofness and long service life on a preferential basis, along with splash proof fans that are inexpensive while retaining a certain level of performance.

To meet such requirements, Sanyo Denki has developed BLDC Splash Proof Fan "WS" Series.

This paper presents an overview and features of the product.

---

## 2. Background of development

---

In conventional practice, when one used a fan motor to cool outdoor equipment forcibly or ventilate a room, one had to make some provision on the installed device to protect the fan motor from direct exposure to wind and rain. One therefore had a hard time coming up with an effective design for the device. Another concern was that, since a fan motor designed for indoor use was used outdoors, it was not sufficiently reliable.

To resolve these problems, Sanyo Denki developed Splash Proof Fan "W" Series in 1996<sup>(1)</sup>. The "W" Series is a family of highly reliable products combining Sanyo Denki's long life fan with high splash-proofness (IPX5). This splash-proofness is achieved mainly by coating the live parts around the motor with silicon.

On the other hand, the market's recent demand for inexpensive fan motors covers splash proof fans as well. It thus became possible to develop fan motors that meet market demand for fan motors whose splash-proofness and service life can be reduced if necessary in order to reduce their prices.

Sanyo Denki then developed BLDC Splash Proof Fan "WS" Series (120mm sq. x 38mm thick, 92mm sq. x 25mm thick, and 80mm sq. x 25mm thick) on the principle of achieving good splash-proofness (IPX4) with the simplest possible motor structure and manufacturing process.

---

## 3. Features and main characteristics of the "WS" Series

---

[Fig.1](#) is an outside view of Splash Proof Fans "WS" Series.

The following is a list of the features of the "WS" Series.

(1)The use of an existing motor model keeps the motor as reliable as earlier models.

(2)Splash-proofness grade of IPX4.

(3)The rotor boss is labyrinth-like and the motor is surrounded by a splash-proof ring, thus minimizing the ingress of water into the motor or bearing.

(4)The series achieves air volume-static pressure characteristics and acoustic noise characteristics equal to those of earlier fan models.

### 3.1 Dimensional specifications

[Fig. 2](#) shows the dimensional specifications of "SAN ACE 120WS."

[Fig. 3](#) shows the dimensional specifications of "SAN ACE 92WS."

[Fig. 4](#) shows the dimensional specifications of "SAN ACE 80WS."

### 3.2 General characteristics

Table 1 shows the general characteristics of "SAN ACE 120WS."

Similarly, Tables 2 and 3 show the general characteristics of "SAN ACE 92WS " and "SAN ACE 80WS."

### 3.3 Splash-proofness specification

The splash-proofness specification of the "WS" Series is the protection class 4 (IPX4) as per JIS C 0920 Appendix - IEC 529 (1989), in either size <sup>(2)</sup>. The testing method for that purpose is illustrated in [Fig. 5](#). The results of the test are summarized in Table 4. This reveals that the fan has problem-free characteristics before and after the test.

**Table 1 General characteristics of "SAN ACE 120WS"**

| Model No.    | Rated voltage (V) | Operating voltage range (V) | Rated current (A) | Rated input (W) | Rated rotating speed (min <sup>-1</sup> ) | Maximum air volume (m <sup>3</sup> /min) | Maximum static pressure (Pa) | Sound pressure level* (dB[A]) | Mass (g) |
|--------------|-------------------|-----------------------------|-------------------|-----------------|---|--|------------------------------|-------------------------------|----------|
| 9WS1212H1021 | 12                | 6 ~ 13.2                    | 0.47              | 5.64            | 2600                                      | 2.9                                      | 67.6                         | 39                            | 260      |
| 9WS1212M1021 |                   | 6 ~ 13.8                    | 0.23              | 2.76            | 1950                                      | 2.2                                      | 42.1                         | 32                            |          |
| 9WS1224H1021 | 24                | 12 ~ 26.4                   | 0.23              | 5.52            | 2600                                      | 2.9                                      | 67.6                         | 39                            |          |
| 9WS1224M1021 |                   | 12 ~ 27.6                   | 0.13              | 3.12            | 1950                                      | 2.2                                      | 42.1                         | 32                            |          |
| 9WS1248H1021 | 48                | 40.8 ~ 52.8                 | 0.13              | 6.24            | 2600                                      | 2.9                                      | 67.6                         | 39                            |          |
| 9WS1248M1021 |                   | 40.8 ~ 55.2                 | 0.07              | 3.36            | 1950                                      | 2.2                                      | 42.1                         | 32                            |          |

\* The sound pressure level is measured 1m from the intake surface of the fan.

**Table 2 General characteristics of "SAN ACE 92WS"**

| Model No.   | Rated voltage (V) | Operating voltage range (V) | Rated current (A) | Rated input (W) | Rated rotating speed (min <sup>-1</sup> ) | Maximum air volume (m <sup>3</sup> /min) | Maximum static pressure (Pa) | Sound pressure level* (dB [A]) | Mass (g) |
|-------------|-------------------|-----------------------------|-------------------|-----------------|---|--|------------------------------|--------------------------------|----------|
| 9WS0912H402 | 12                | 10.2 ~ 13.8                 | 0.17              | 2.04            | 2850                                      | 1.38                                     | 45.1                         | 33                             | 150      |
| 9WS0912F402 |                   |                             | 0.13              | 1.56            | 2450                                      | 1.18                                     | 32.3                         | 30                             |          |
| 9WS0912M402 |                   |                             | 0.10              | 1.20            | 2100                                      | 1.01                                     | 23.5                         | 27                             |          |
| 9WS0912L402 |                   |                             | 0.06              | 0.72            | 1700                                      | 0.80                                     | 16.7                         | 23                             |          |
| 9WS0924H402 | 24                | 20.4 ~ 27.6                 | 0.10              | 2.40            | 2850                                      | 1.38                                     | 45.1                         | 33                             |          |
| 9WS0924F402 |                   |                             | 0.07              | 1.68            | 2450                                      | 1.18                                     | 32.3                         | 30                             |          |
| 9WS0924M402 |                   |                             | 0.06              | 1.44            | 2100                                      | 1.01                                     | 23.5                         | 27                             |          |
| 9WS0924L402 |                   |                             | 0.05              | 1.20            | 1700                                      | 0.80                                     | 16.7                         | 23                             |          |

\* The sound pressure level is measured 1m from the intake surface of the fan.

**Table 3 General characteristics of "SAN ACE 80WS"**

| Model No.   | Rated voltage (V) | Operating voltage range (V) | Rated current (A) | Rated input (W) | Rated rotating speed (min <sup>-1</sup> ) | Maximum air volume (m <sup>3</sup> /min) | Maximum static pressure (Pa) | Sound pressure level* (dB [A]) | Mass (g) |
|-------------|-------------------|-----------------------------|-------------------|-----------------|---|--|------------------------------|--------------------------------|----------|
| 9WS0812H402 | 12                | 10.2 ~ 13.8                 | 0.16              | 1.92            | 3100                                      | 0.94                                     | 45.1                         | 32                             | 120      |
| 9WS0812F402 |                   |                             | 0.13              | 1.56            | 2700                                      | 0.83                                     | 34.2                         | 28                             |          |
| 9WS0812M402 |                   |                             | 0.10              | 1.20            | 2200                                      | 0.65                                     | 23.5                         | 23                             |          |
| 9WS0824H402 | 24                | 20.4 ~ 27.6                 | 0.09              | 2.16            | 3100                                      | 0.94                                     | 45.1                         | 32                             |          |
| 9WS0824F402 |                   |                             | 0.07              | 1.68            | 2700                                      | 0.83                                     | 34.2                         | 28                             |          |
| 9WS0824M402 |                   |                             | 0.05              | 1.20            | 2200                                      | 0.65                                     | 23.5                         | 23                             |          |

\* The sound pressure level is measured 1m from the intake surface of the fan.

**Table 4 Comparison table of characteristics before and after a splash-proofness test**

Voltage applied: 12V

| Dimensions | Model No.    | Rotating speed (min <sup>-1</sup> ) |       | Current (A) |       | Sound pressure level (dB [A]) |       | Dielectric strength |       | Insulation resistance |       |
|------------|--------------|-------------------------------------|-------|-------------|-------|-------------------------------|-------|---------------------|-------|-----------------------|-------|
|            |              | Before                              | After | Before      | After | Before                        | After | Before              | After | Before                | After |
| 120mm sq.  | 9WS1212H1021 | 2590                                | 2600  | 0.452       | 0.454 | 39.5                          | 39.5  | OK                  |       | OK                    |       |
| 92mm sq.   | 9WS0912H401  | 2820                                | 2820  | 0.155       | 0.155 | 32                            | 32    |                     |       |                       |       |
| 80mm sq.   | 9WS0812H401  | 3060                                | 3040  | 0.147       | 0.146 | 32                            | 32    |                     |       |                       |       |

Note 1: The sound pressure level is measured 1m from the surface of the equipment.

Note 2: Dielectric strength: 50/60Hz AC, 500V, 1 minute (between input and frame)

Note 3: Insulation resistance: 10M Ω or more as measured with a 500V DC megger (between input and frame).

## 4. Structure of splash proof fan

The Splash Proof Fan "WS" Series employs the structure illustrated below to ensure splash-proofness.

[Fig. 6](#) illustrates the structure of the motor of "SAN ACE 120WS." [Fig. 7](#) illustrates the structure of the motor used in "SAN ACE 92WS" and "SAN ACE 80WS" (patents applied for).

### 4.1 Labyrinth structure

An ordinary fan motor has a gap between a rotor and frame boss, and water would enter the motor through the gap. To prevent this, the "WS" Series employs a labyrinth structure for the edge of the rotor and the perimeter of the frame boss, thus minimizing the entry of water into the motor.

### 4.2 Splash proof ring

The labyrinth structure described above may not be functionally sufficient depending on which way the fan motor is oriented for use. For this reason, a splash proof ring is incorporated between the perimeter of the PCB in the motor and the labyrinth. As a result, water that enters through the labyrinth is sheltered by the ring. Instead of entering the motor, it flows out of the motor through the clearance between the rotor and frame boss.

The frame of the fan motor is made of an integrally molded resin. The splash proof ring however, is designed so that it is difficult to mold integrally with the frame. The authors therefore decided to mold the ring separately from the frame and join them together at a later stage. The joint was made by ultrasonic welding to make sure that the joint was watertight and to shorten the time required for the joint process.

## 5. Conclusion

---

This paper presents part of the structure and performance of the "WS" Series newly developed by the company.

A line-up of two splash proof fan models has now been born, from the traditional Splash Proof Fan "W" Series and the newly-developed "WS" Series. This allows users to use the two different models depending on their particular purpose. The authors therefore hope that these models will be able to meet a wide range of customer requirements for cooling equipment used outdoors and equipment vulnerable to splashes or ventilating the room.

### References

(1)Osawa et al.: Development of Splash Proof Fans  
SANYO DENKI Technical Report, No.3, pp.6-8 (1997-5).

(2)Tests to prove protection against ingress of water and degress of protection against ingress of solid objects for electrical equipment as per JIS C 0920,Appendix – IEC 529(1989)

---

### Michinori Watanabe

Joined company in 1989  
Cooling Systems Division, Design Dept.  
Worked on development and design of fan motors

### Kesatsugu Watanabe

Joined company in 1973  
Cooling Systems Division, Design Dept.  
Worked on development and design of fan motors

### Minoru Fujiwara

Joined company in 1981  
Cooling Systems Division, Design Dept.  
amplifiers, then on development and design of fan motors

### Satoshi Fujimaki

Joined company in 1982  
Cooling Systems Division, Design Dept.  
Worked on development of  
uninterruptible power supply units,  
then on development and design of fan motors

### Michihiro Suzuki

Joined company in 1989  
Cooling Systems Division, Design Dept.  
Worked on production engineering, then on  
development and design of fan motors

### Takashi Kaise

Joined company in 1990  
Cooling Systems Division, Design Dept.  
Worked on development and design of fan motors

### Naruhiko Kudou

Joined company in 1997  
Cooling Systems Division, Design Dept.  
Worked on production engineering, then on  
development and design of fan motors

---



fig.1 Outside view of Splash Proof Fans "WS" Series

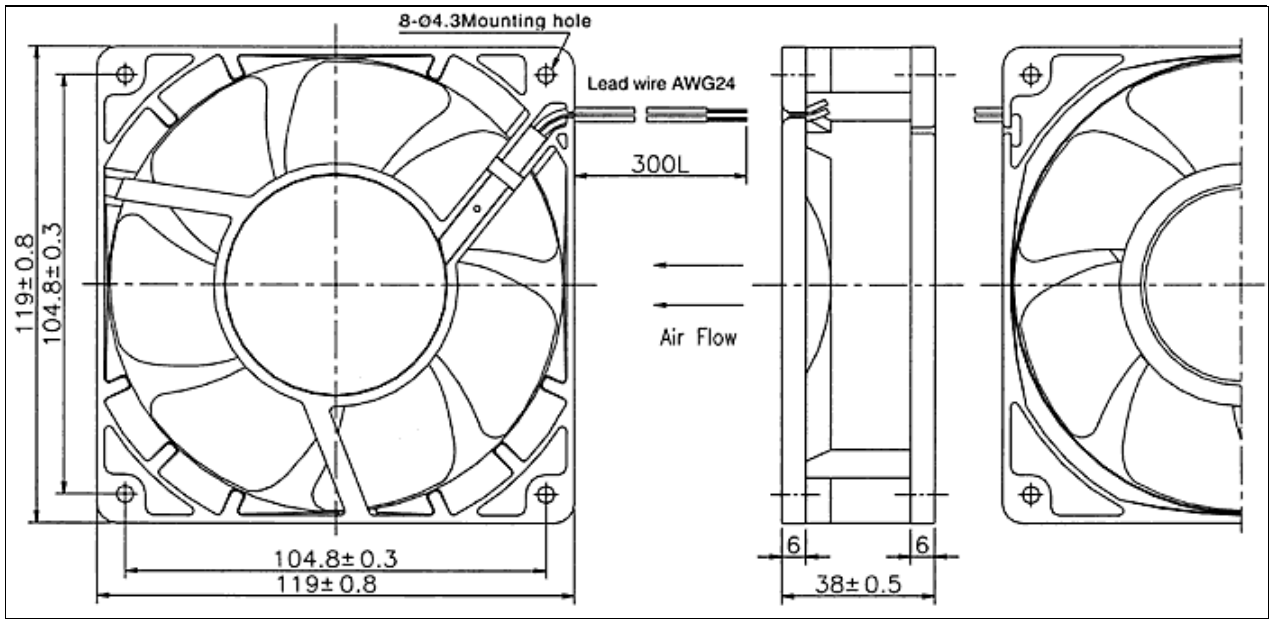

fig.2 Dimensional specifications of "SAN ACE 120WS"

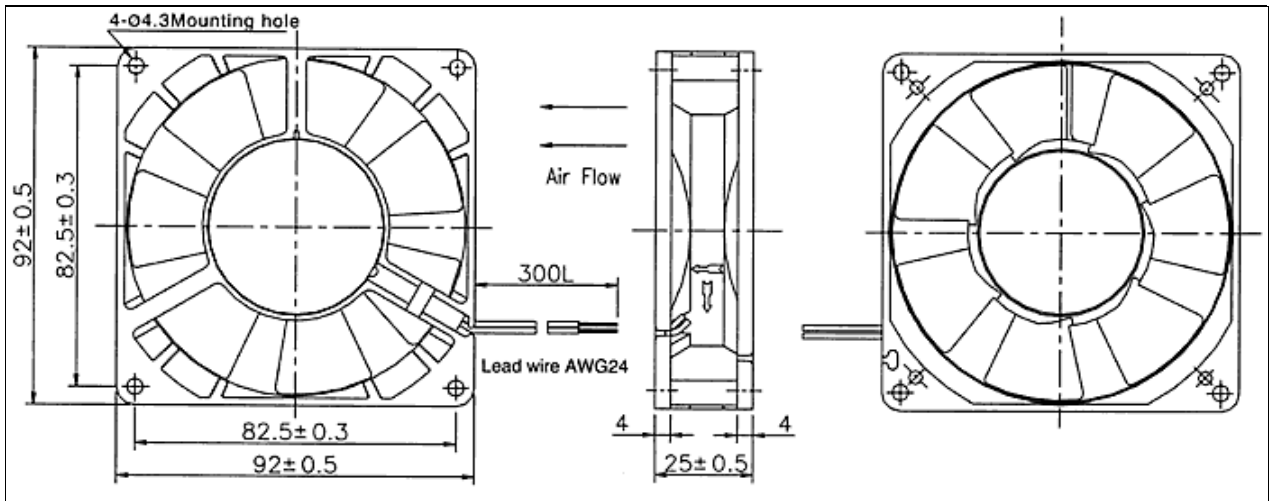

fig.3 Dimensional specifications of "SAN ACE 92WS"

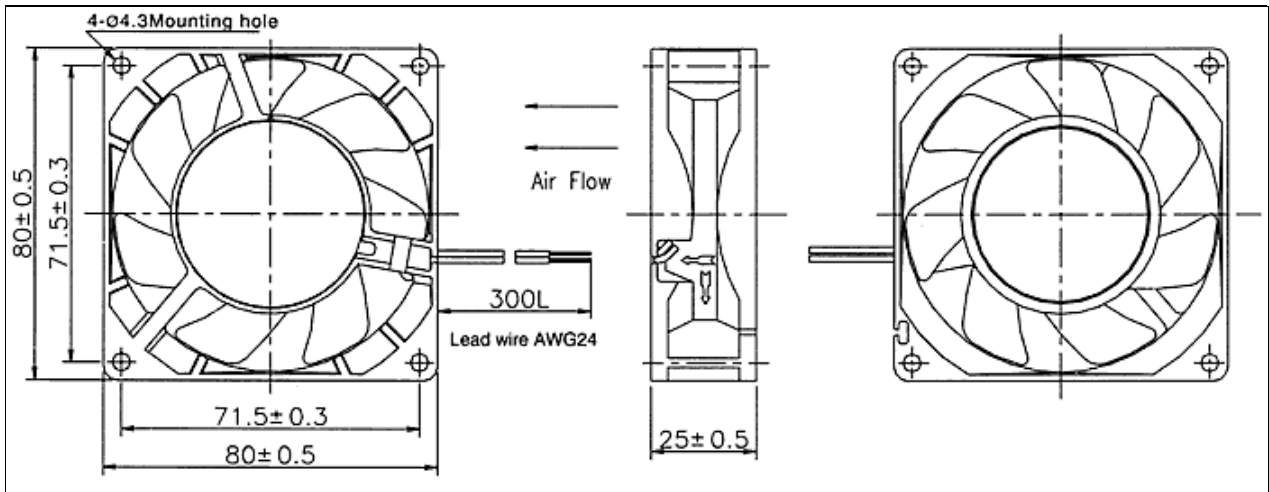

fig.4 Dimensional specifications of "SAN ACE 80WS"



**Splash-proofness test (testing on IPX4 splashes as per IEC 529-1989)**  
 Position the test specimen in a normal installed condition. Then sprinkle water over the entire range up to 180 degrees on both sides from the vertical, from a height of up to 200mm above the test specimen, by means of an oscillating tube (sprinkling tester) under the conditions specified in the table below. The testing time is 10 minutes.

| Item                       | Condition   |
|----------------------------|-------------|
| Radius of oscillating tube | 200mm       |
| Total water flow           | 0.84 L/min. |
| Number of open holes       | 12          |
| Average flowrate per hole  | 0.07 L/min. |

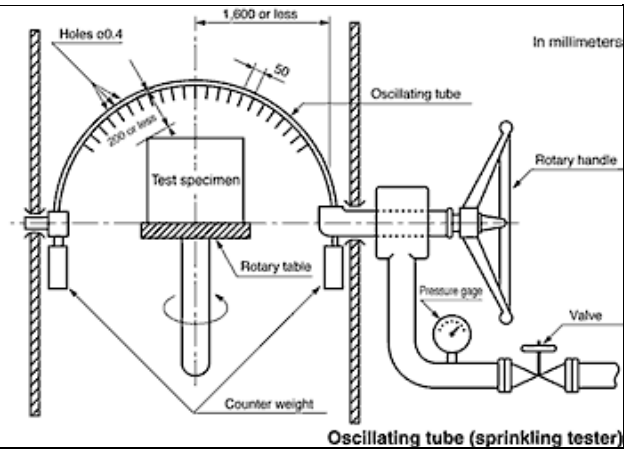

fig.5 Splash-proofness testing for the protection class 4 (IPX4) as per IEC 529

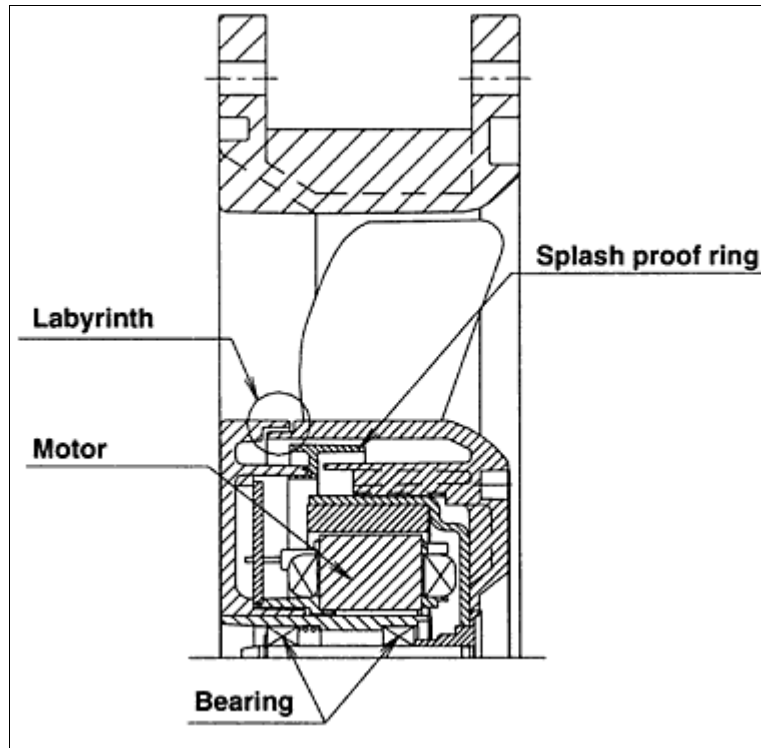

fig.6 Structure drawing of "SAN ACE 120WS"

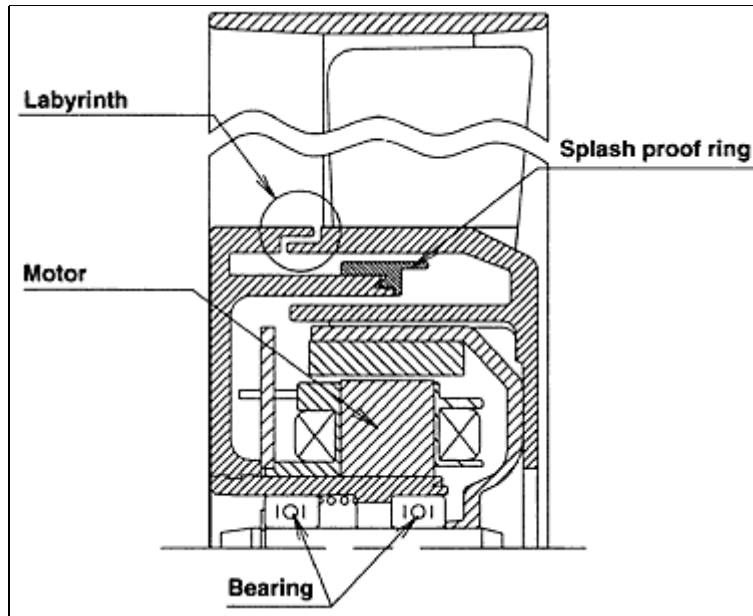

fig.7 Structure drawing of the motor in "SAN ACE 92WS" and "SAN ACE 80WS"