

Data Center Applications

San Ace

SANUPS

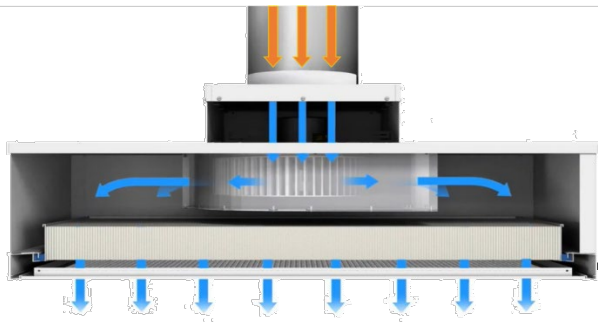

Fan Filter Units HVAC
Large Centrifugal Fans

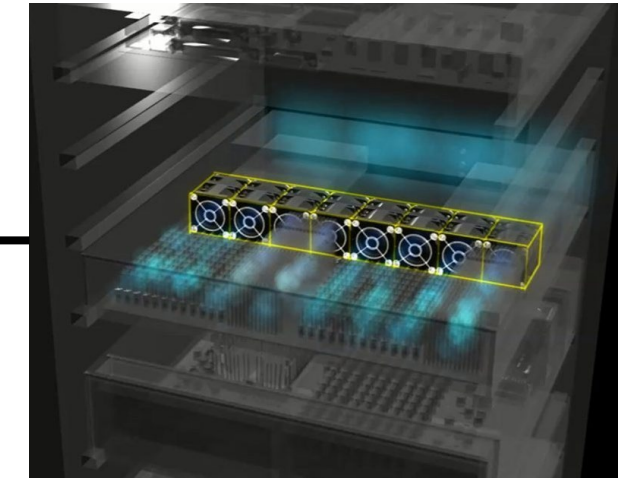
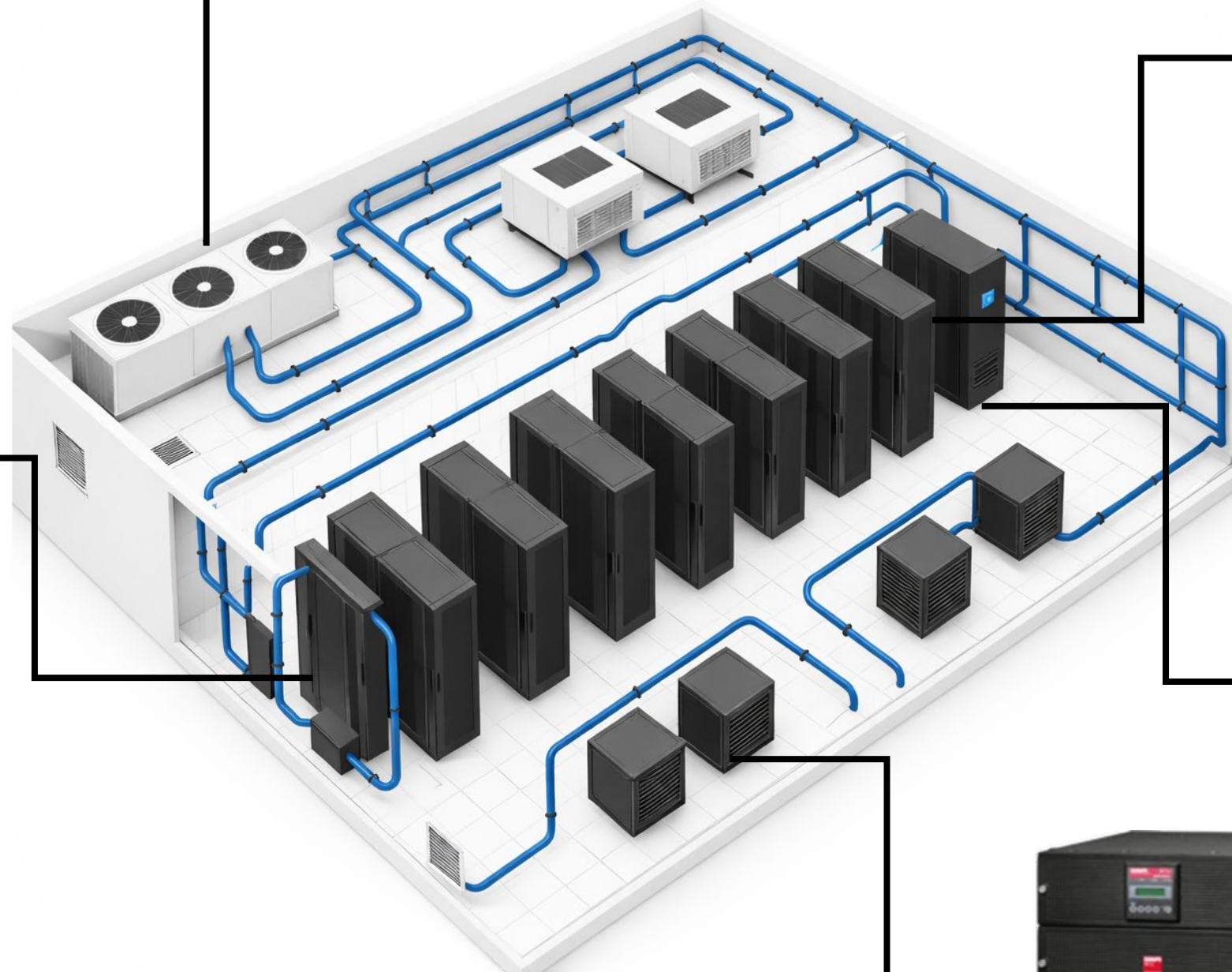

**1RU, 2RU, 3RU Servers,
Switches, Storage**
High Performance Cooling Fans



**Rear Door Heat Exchangers
(RDHx) Active Cooling**
Large Airflow Axial Fans



**Uninterruptible Power Supply
(UPS) & Energy Storage**
UPS Systems for 100% Uptime



SANYO DENKI

San Ace

Counter Rotating Fan

For high static pressure and high airflow

Lineup

- 40mm
- 60mm
- 80mm
- 92mm
- 120mm
- Φ172mm

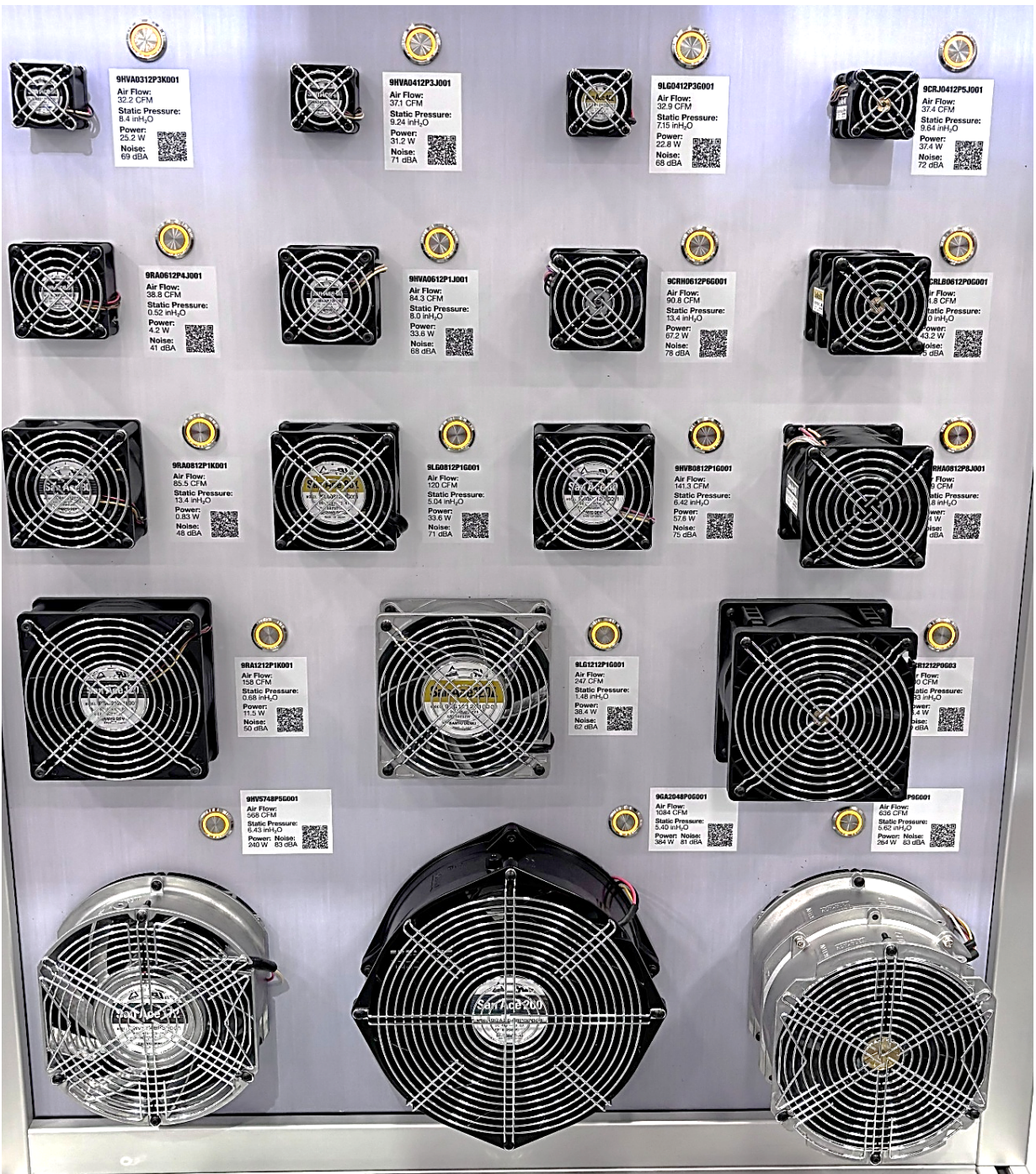

40mm

- High RPM & Airflow
- High Performance
- Compact Design
- Hot-Swappable e-Brake
- 12V and 48V Options



60mm

- High RPM & Airflow
- High Performance
- Versatile Design
- Power Efficient
- Long Life Options



80mm

- High RPM & Airflow
- High Performance
- Heavy-Duty Design
- Hot-Swappable e-Brake
- 12V and 48V Options
- Long Life Options



120mm

- High Airflow
- High Performance
- Robust Design
- Power Efficient
- Low Noise



Centrifugal & Splash Proof

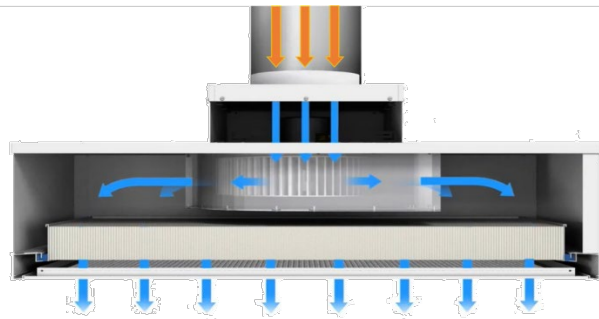

- High Airflow
- 360° Radial Airflow
- Splash Proof up to IP56 & IP68

► DC Centrifugal Fan

Lineup

Φ70mm Φ100mm Φ133mm Φ150mm Φ175mm
Φ221mm Φ225mm □270mm(with a ø225mm bracket mounted)

► ACDC Centrifugal Fan

Lineup

Φ190mm Φ225mm Φ250mm
□270mm(with a ø225 mm bracket mounted)

Controller powered by fan +10 VDC output;
no external DC supply required. IP56 available.

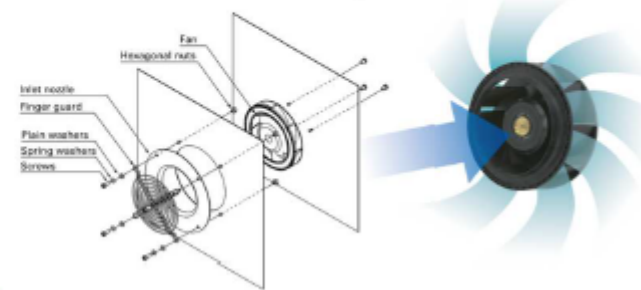

When mounting a Centrifugal Fan, a dedicated inlet nozzle is needed. Air is drawn in axially and discharged radially in 360° directions

Regular fan



IP68-rated fan



Low Power Consumption Fan

San Ace 200 9GA type



Φ200 × 70 mm

- Power Savings
- High Airflow & Performance
- Integration into Coolant Distribution Units (CDUs)



SANUPS

UPS FOR DATA CENTER INFRASTRUCTURE

Rack-mountable SANUPS systems help support uptime for servers, switches, storage, and network infrastructure.

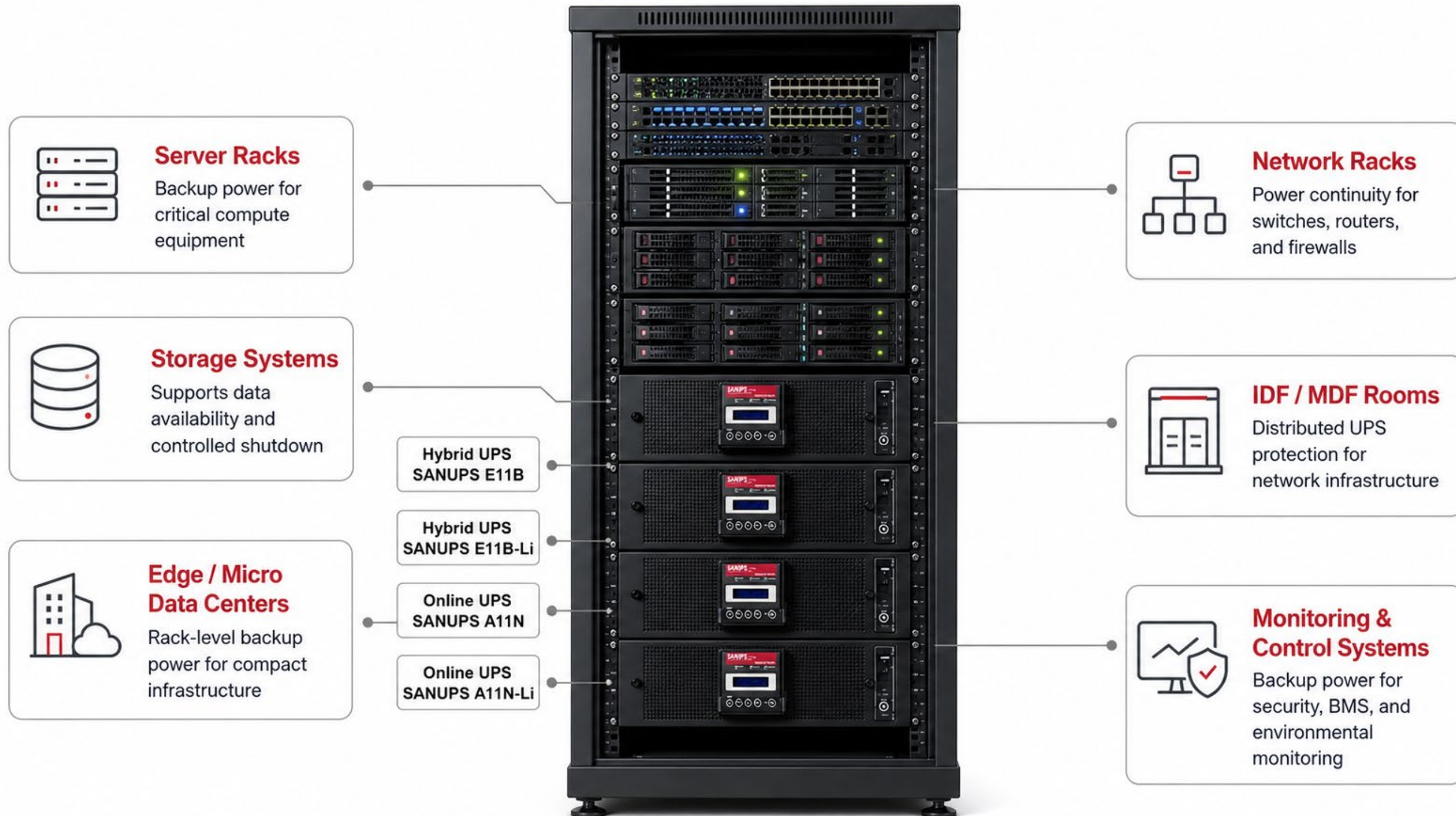

SANUPS



RACK-MOUNT UPS LINEUP

LEAD-ACID BATTERY



SANUPS E11B-Li

120V model: 1.0kVA, 1.5kVA, 2.0kVA, 3.0kVA
208V model: 1.0kVA, 2.0kVA, 3.0kVA

Best for: Cost-conscious rack-mount backup power

LITHIUM-ION BATTERY



SANUPS E11B-Li

120V model: 1.0kVA, 1.5kVA, 2.0kVA
208V model: 1.0kVA, 2.0kVA

Best for: Long-life backup power with lithium-ion batteries

HYBRID UPS

Switches operating modes to balance efficiency and power protection

ONLINE UPS

Double-conversion design continuously supplies conditioned power



SANUPS A11N

208V model: 5.0kVA, 10.0kVA

Best for: Higher-capacity online UPS protection



SANUPS A11N-Li

208V model: 5.0kVA, 10.0kVA

Best for: Higher-capacity online UPS protection with lithium-ion longevity