

# SANMOTION

STEPPING SYSTEMS

# STEPPING MOTOR WITH ENCODER

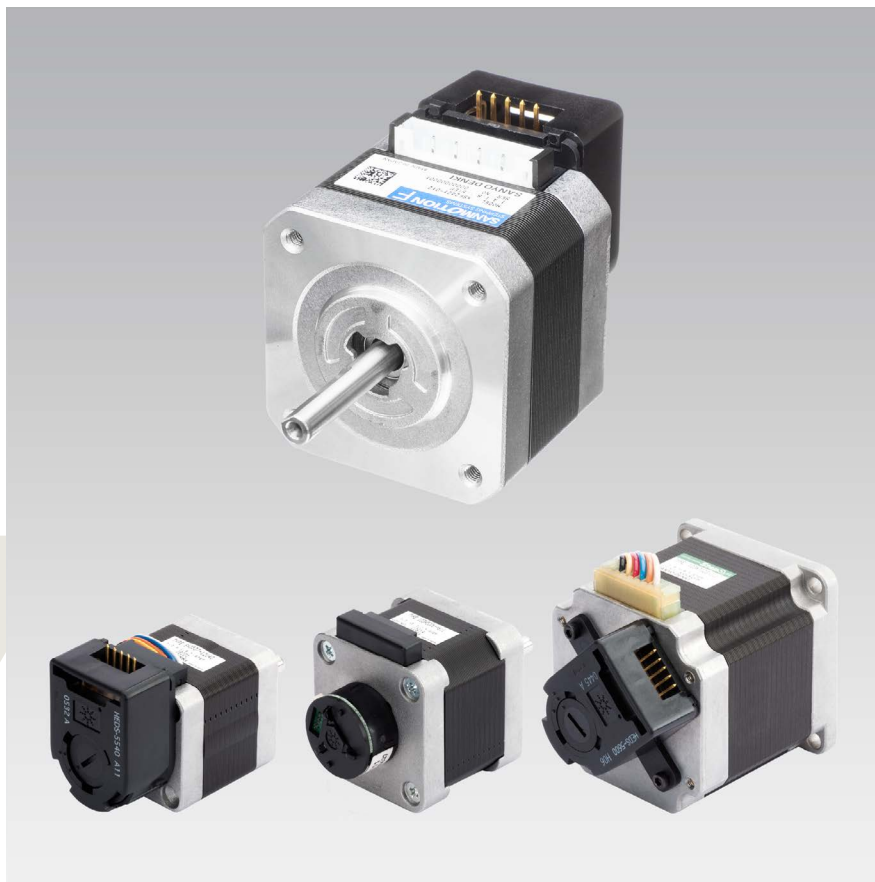

**SANYO DENKI**

**Ver.3**

STEPPING SYSTEMS

# STEPPING MOTOR WITH ENCODER



Standard Models



Quick Customization Service

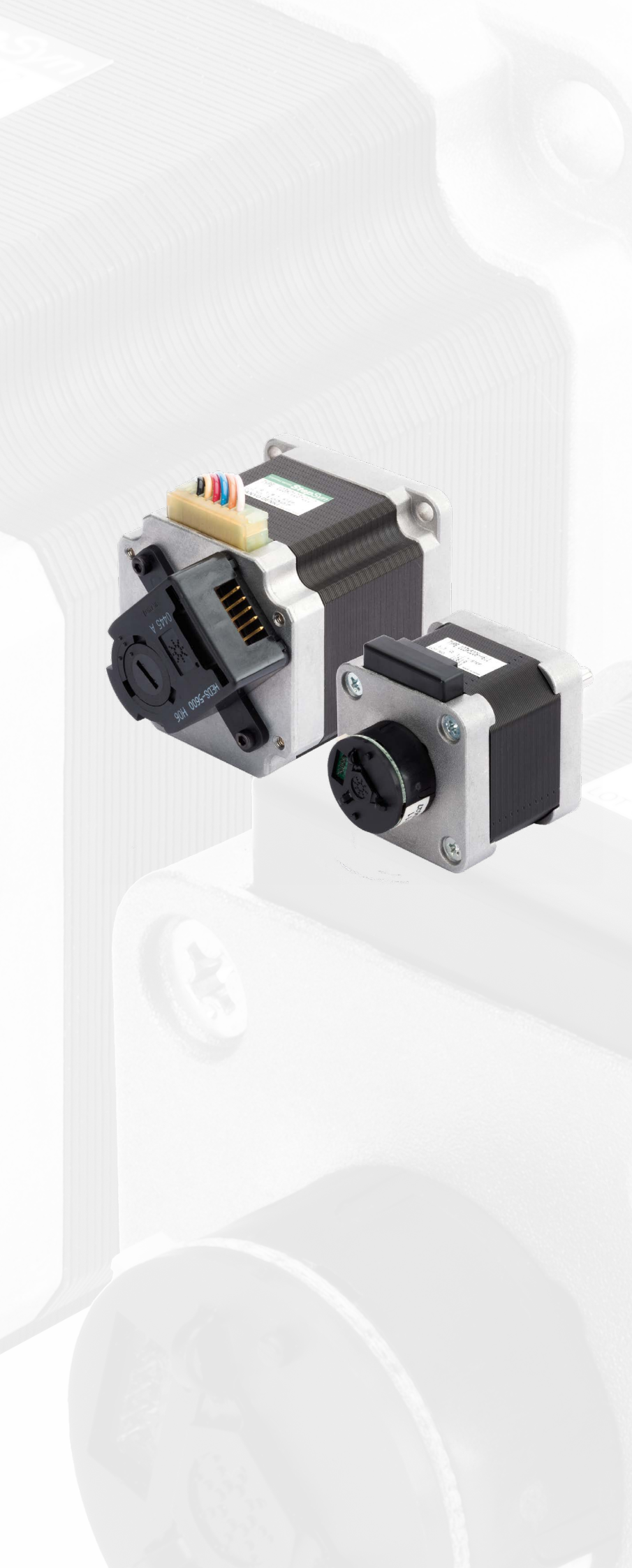

## Contents

Features .....	p. 4
Application examples .....	p. 5
Stepping motors lineup .....	p. 5
Encoder selection guide .....	p. 5
How to read part numbers .....	p. 6
Part numbers available .....	p. 7

## Standard Models

35mm. sq models .....	p. 8
42mm. sq models .....	p. 10
56mm. sq models .....	p. 15
60mm. sq models .....	p. 18
86mm. sq models .....	p. 20
Encoder specifications .....	p. 22
Type R .....	p. 22
Type S .....	p. 23
Type M.....	p. 24
Type L .....	p. 25
General specifications .....	p. 26
Wiring and rotation direction .....	p. 27

## Quick Customization Service

Easy customization .....	p. 28
Quick customization .....	p. 29
Customization examples .....	p. 29
Inquiry Check Sheet .....	p. 30

# STEPPING MOTOR WITH ENCODER

## When open-loop control is not enough

Stepping systems provide precise positioning with easy control. By adding an encoder to a stepping motor, the controller can monitor the actual position directly, closing the feedback loop and improving the safety and reliability.

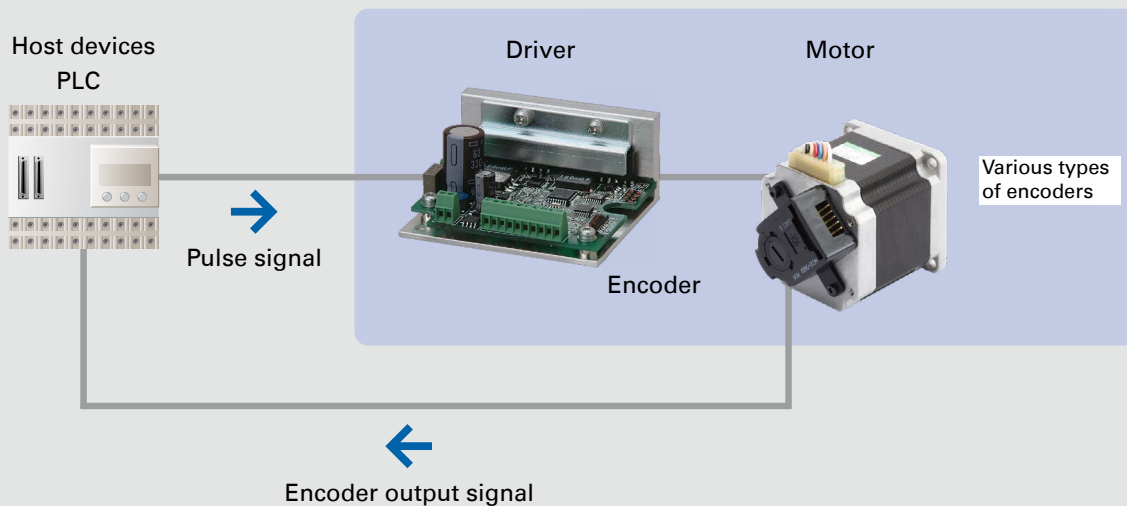

## Stepping Motor with Encoder: Features

### Safety: Position verification

Adding an encoder is an ideal and easy solution for safety-sensitive applications, requiring position verification and position maintenance, such as medical instrumentation.

### Close-loop control with stepper benefit

High-end close loop control can be achieved while keeping the advantages of stepping motors: stable stop without hunting, higher torque than DC servo motor at low speed over the same size, eliminating the need of gearboxes.

### Reliability: Stall Detection

Device reliability is improved with possible detection and reporting of stalls.

### Accurate Homing

Encoder with index pulse option can be used to achieve precise homing.



We also provide quick customization service to meet your particular need. Contact our sales office for information.

Quick Customization Service ▶ p. 28  
Inquiry Check Sheet ▶ p. 30

# Application Examples



Blood Analyser

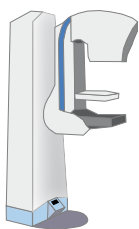

Mammograph









3D Printing







Industrial machine

## Stepping Motors: Lineup RoHS

Motor size		Holding torque [Nm min.]	Basic step angle	Model number	Page
35 mm sq.		0.195 to 0.23	1.8°	2H35□	p. 8
42 mm sq.		0.29 to 0.8	1.8°	2F42□	p. 10
42 mm sq.		0.26 to 0.42	1.8°	2H42□	p. 12
		0.23	0.9°	2P42□	
56 mm sq.		0.83 to 2	1.8°	2H56□	p. 15
60 mm sq.		0.88 to 2.7	1.8°	2H60□	p. 18
86 mm sq.		3.3 to 9	1.8°	2H86□	p. 20

## Encoder Selection Guide RoHS

4 types of encoder can be selected. They are two and three channels optical incremental encoders and emphasize high reliability and high resolution.

Encoder type	Counts Per Revolution [CPR]				Pulse index option	Single ended	Differential line driver	Key points
	200	400	1000	1024				
<b>R</b> <sub>type</sub> 	■					■		Compact size Simple interface Cost effective
<b>S</b> <sub>type</sub> 		■			■	■		Medium resolution Pulse index option Simple interface
<b>M</b> <sub>type</sub> 			■	■	■	■		High resolution Pulse index option Simple interface
<b>L</b> <sub>type</sub> 		■					■	Noise immunity Transmitting encoder signal over a long distance

Encoder specifications ▶ p. 22 to 25  
Please consult us for higher resolution encoder

# How to Read Part Numbers

Note that not every combination of the following codes or characters is available. Check the part numbers available on the following or contact us.

Example: This is a standard model number for a stepping motor and encoder. The motor specifications are 2-phase stepping motor, motor size: 56mm sq., motor length: 54mm, bipolar winding, 2A/phase, S type encoder, 2 channels, 400 CPR.

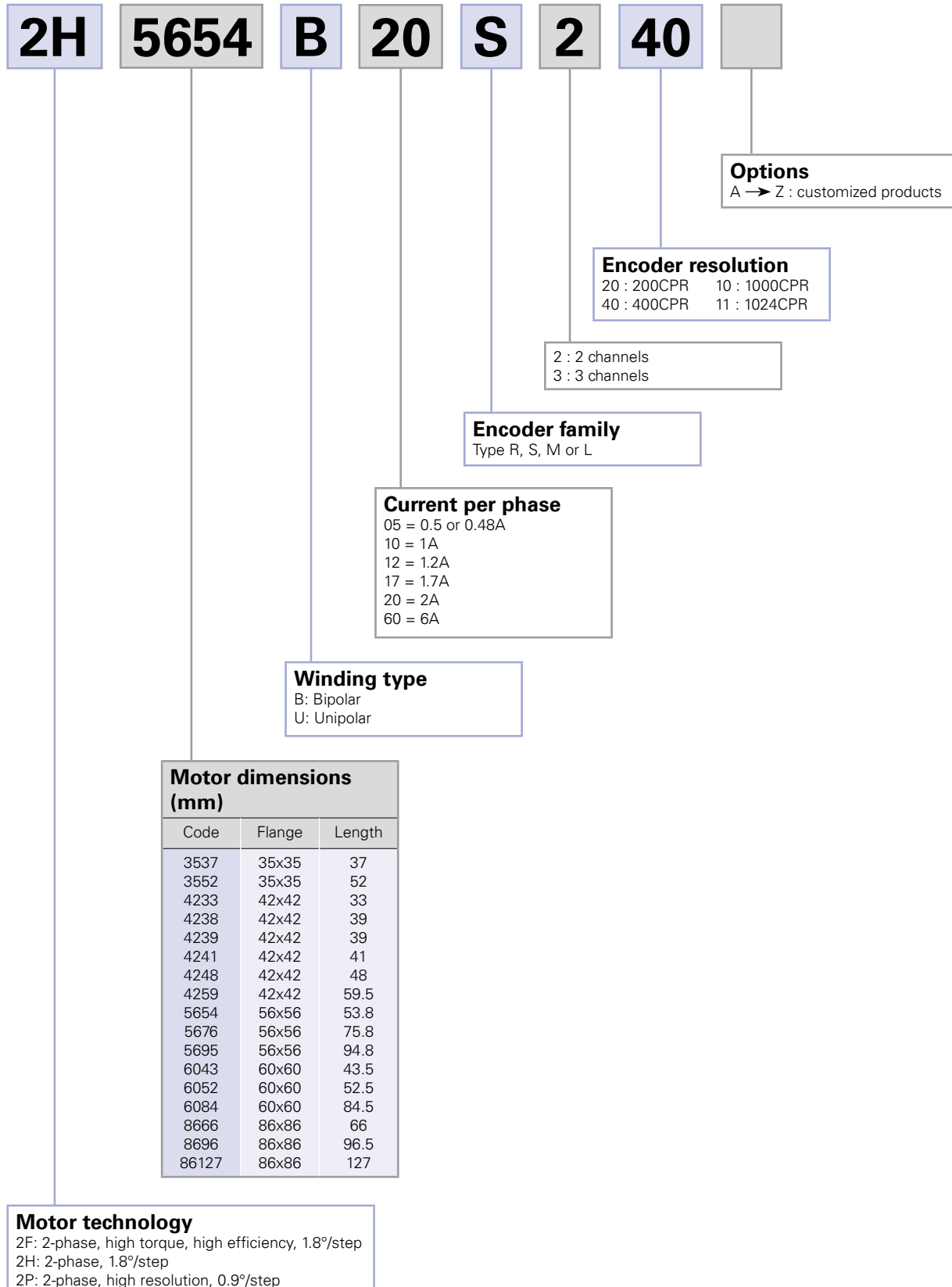

# Part Numbers Available

On below table are introduced available combinations between stepping motors and encoders.

- : Standard combinations, available from stock  
 ○ : On demand

Motor size	Based motor	Encoder type						Page	
		R type	S type		M type		L type		
		2 channels	2 channels	3 channels	2 channels		3 channels		2 channels
		200CPR	400CPR	400CPR	1000CPR	1024CPR	1000CPR		400CPR
		R220	S240	S340	M210	M211	M310	L240	
35 mm sq.	2H3537B12	■	■	■	■	■	■		p. 8
	2H3552U12	■	■	■	■	■	■		p. 8
42 mm sq.	2F4233B10		■	■	■	■	■		p. 10
	2F4239B10		■	■	■	■	■		p. 10
	2F4248B10		■	■	■	■	■		p. 10
	2F4259B10		■	■	■	■	■		p. 10
	2H4233B05	■	○	○	○	○	○		p. 12
	2H4238B17	■	○	○	○	○	○		p. 12
	2H4241B05		○	○	○	○	○		p. 12
	2H4241U12		○	○	○	○	○		p. 12
	2H4248U12	■	○	○	○	○	○		p. 12
	2P4233B10		■	■	■	■	■		p. 12
56 mm sq.	2H5654U10	■	■	■	■	■		■	p. 15
	2H5654U20	■	■	■	■	■		■	p. 15
	2H5654B20		■	■	■	■		■	p. 15
	2H5676B20		■	■	■	■		■	p. 15
	2H5695B20	■	■	■	■	■		■	p. 15
60 mm sq.	2H6043B20	■	■	■	■	■		■	p. 18
	2H6052B20	■	■	■	■	■		■	p. 18
	2H6084B20	■	■	■	■	■		■	p. 18
86 mm sq.	2H8666B60	■	■	■	■	■		■	p. 20
	2H8696B60	■	■	■	■	■		■	p. 20
	2H86127B60	■	■	■	■	■		■	p. 20

## Optional Cables

### Motor cables

Motor size	Based motor	Cable P/N
42 mm sq.	2F42xxBxx	4835775-1
	2H42xxBxx	4835728-1
	2H42xxUxx	4835710-1

### Encoder cables

Encoder	Motor type	Cable P/N
R220	2H35, 2H42	CRP12500
	2H56, 2H60, 2H86	CRS22500
Sxxx Mxxx	all	CS3500





**2H3552U12R220**

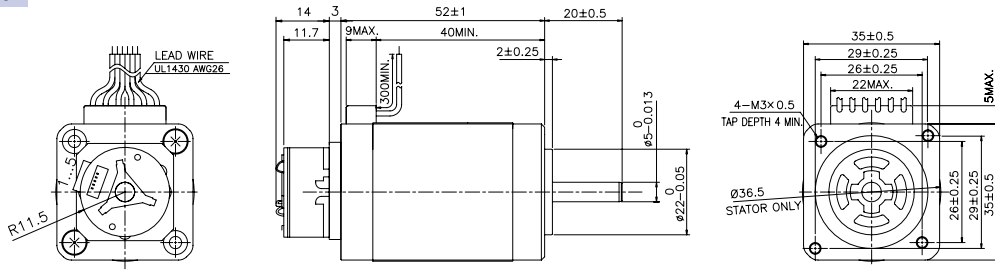

**2H3552U12Sxxx**  
**2H3552U12Mxxx**

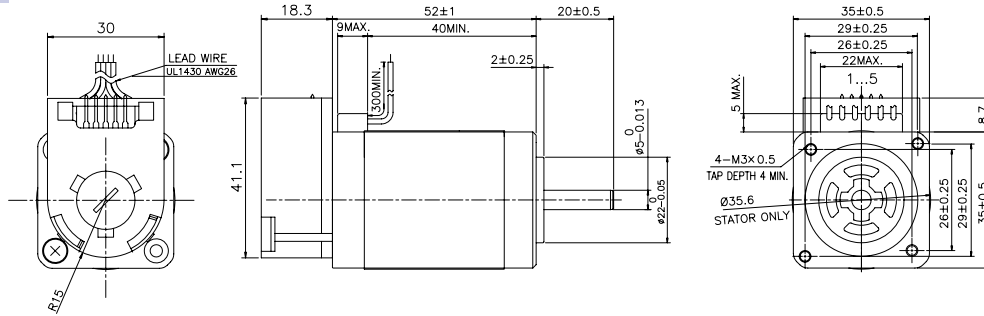

**Internal wiring**

Unipolar winding

Bipolar winding

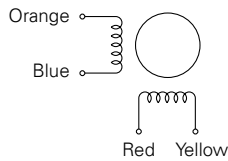
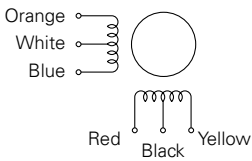

General Specification ▶ p. 26  
Rotation Direction ▶ p. 27

**Encoder cables**

R220 Encoder, Cable P/N: CRP12500

Manufacturer: MOLEX  
Housing: 51021-0500  
Terminal: 50079-8000 or 8100

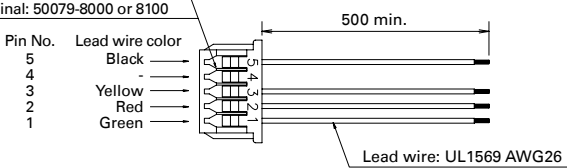

Sxxx, Mxxx Encoder, Cable P/N: CS3500

Manufacturer: MOLEX  
Housing: 22-01-2055  
or 22-01-3057

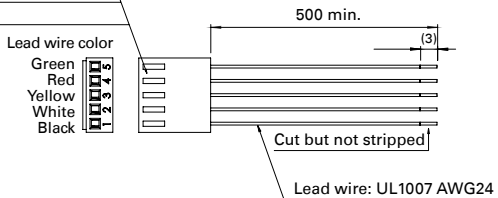

35mm sq.

42mm sq.

56mm sq.

60mm sq.

86mm sq.

Encoder Specifications

Customization Service



## 42 mm sq.

1.8° /step RoHS

Bipolar winding  
Connector type

Based motor	Holding torque at 2-phase energization [N.m min.]	Step angle °	Winding type	Rated current A/phase	Wiring resistance Ω /phase	Winding inductance mH/phase	Rotor Inertia [ $\times 10^{-4}$ kg.m <sup>2</sup> ]	Weight kg	Optional motor cable
<b>2F4233B10</b>	0.29	1.8	Bipolar	1	3.6	7	0.031	0.23	4835775-1
<b>2F4239B10</b>	0.43	1.8	Bipolar	1	4.6	9.6	0.046	0.30	4835775-1
<b>2F4248B10</b>	0.56	1.8	Bipolar	1	5.3	12.5	0.063	0.38	4835775-1
<b>2F4259B10</b>	0.8	1.8	Bipolar	1	6.5	16	0.094	0.51	4835775-1

- For quantities higher than 104 pcs/lot, the encoder is directly mounted on the motor.
- For quantities equal or less than 104 pcs/lot an adaptation plate is used for the encoder mounting. The part numbers of motors with adaptation plate end with A and dimensions differ.

### Dynamic performances

#### 2F4233B10

Driver: BS1D200P10  
Power supply: — 36V — 24V  
Current: 1A/phase unipolar  
Excitation mode: Full-step  
Load inertia JL =  $0.94 \times 10^{-4}$  Kg.m<sup>2</sup> (rubber coupling)

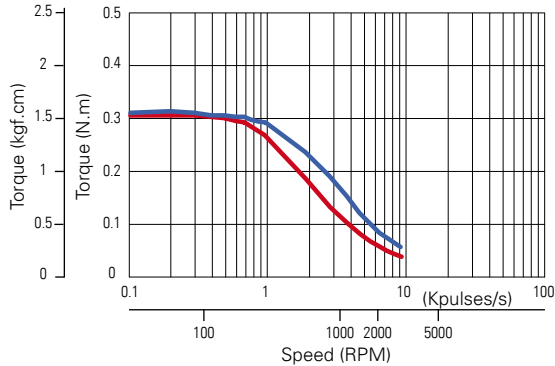

#### 2F4239B10

Driver: BS1D200P10  
Power supply: — 36V — 24V  
Current: 1A/phase unipolar  
Excitation mode: Full-step  
Load inertia JL =  $0.94 \times 10^{-4}$  Kg.m<sup>2</sup> (rubber coupling)

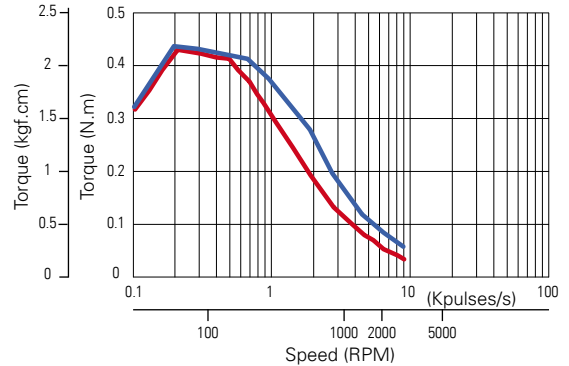

#### 2F4248B10

Driver: BS1D200P10  
Power supply: — 36V — 24V  
Current: 1A/phase unipolar  
Excitation mode: Full-step  
Load inertia JL =  $0.94 \times 10^{-4}$  Kg.m<sup>2</sup> (rubber coupling)

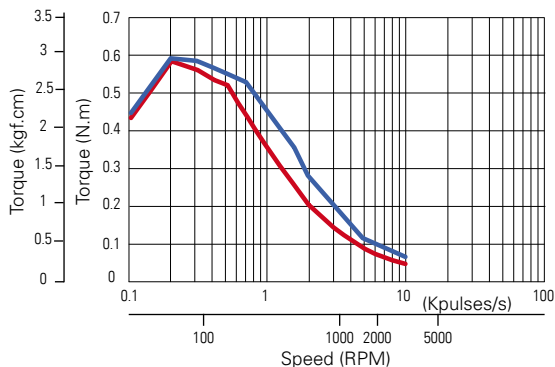

#### 2F4259B10

Driver: BS1D200P10  
Power supply: — 36V — 24V  
Current: 1A/phase unipolar  
Excitation mode: Full-step  
Load inertia JL =  $2.6 \times 10^{-4}$  Kg.m<sup>2</sup> (rubber coupling)

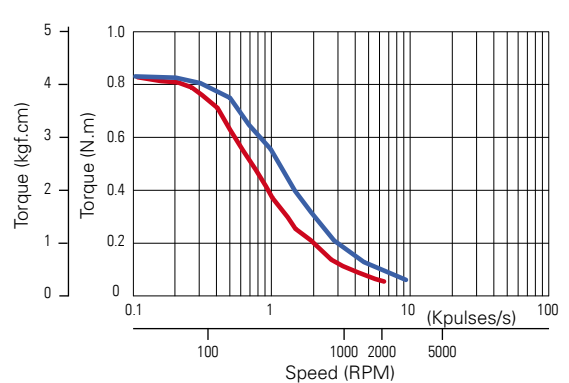

## Dimensions with direct mounting [Unit: mm]

2F42xxxxSx40  
2F42xxxxMx1x

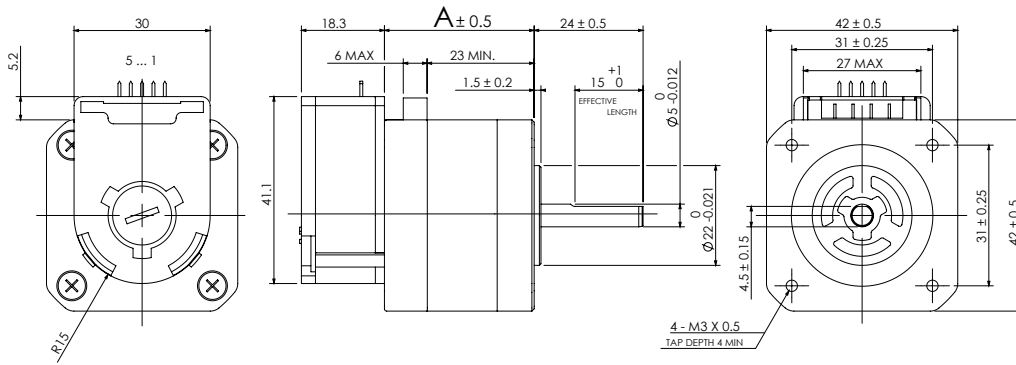

## Dimensions with adaptation plate [Unit: mm]

2F42xxxxSx40A  
2F42xxxxMx1xA

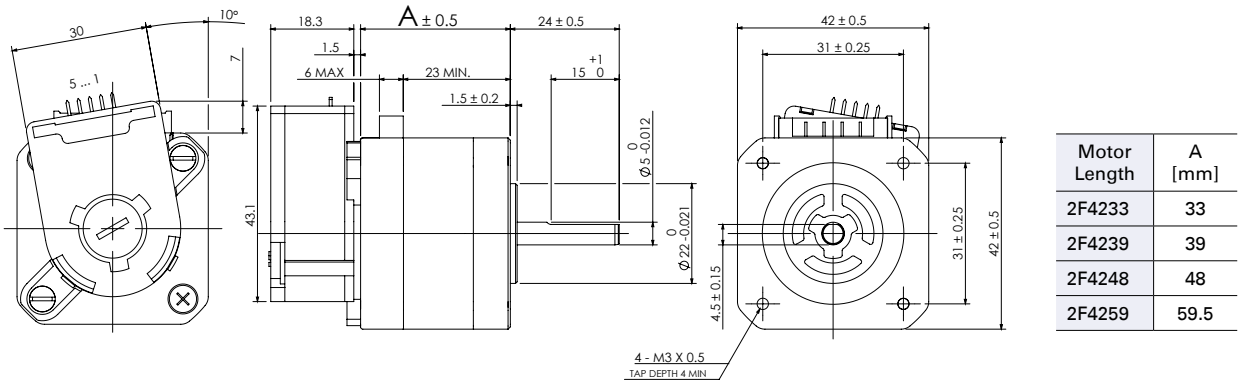

## Internal wiring

( ) connector pin number

Bipolar winding

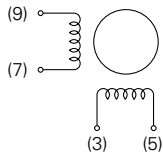

General Specification ▶ p. 26  
Rotation Direction ▶ p. 27

## Motor cable

Cable P/N: 4835775-1

Manufacturer: J.S.T.  
Housing: PHR-11  
Pin: SPH-002T-P0.5S

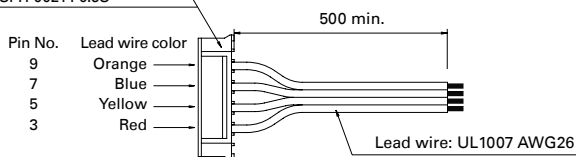

## Encoder cables

Sxxx, Mxxx Encoder, Cable P/N: CS3500

Manufacturer: MOLEX  
Housing: 22-01-2055  
or 22-01-3057

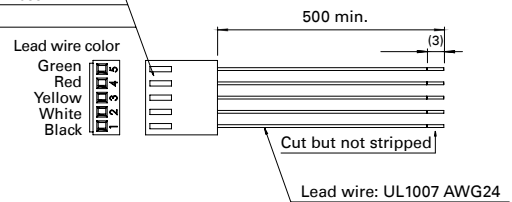

35mm sq.

42mm sq.

56mm sq.

60mm sq.

86mm sq.

Encoder Specifications

Customization Service



## 42 mm sq.

0.9° - 1.8° /step RoHS

Unipolar and Bipolar winding  
Lead wire and Connector type

Based motor	Holding torque at 2-phase energization	Step angle °	Winding type	Rated current A/phase	Wiring resistance Ω /phase	Winding inductance mH/phase	Rotor Inertia [x 10 <sup>-4</sup> kg.m <sup>2</sup> ]	Weight kg	Optional motor cable
	[N.m min.]								
<b>2P4233B10</b>	0.23	0.9	Bipolar	1	3.3	8.0	0.044	0.24	-
<b>2H4233B05</b>	0.26	1.8	Bipolar	0.48	14	27	0.036	0.23	4835728-1
<b>2H4238B17</b>	0.39	1.8	Bipolar	1.7	1.3	3.4	0.056	0.29	4835728-1
<b>2H4241B05</b>	0.42	1.8	Bipolar	0.5	18	42	0.062	0.31	4835728-1
<b>2H4241U12</b>	0.32	1.8	Unipolar	1.2	3	3.9	0.062	0.31	4835710-1
<b>2H4248U12</b>	0.37	1.8	Unipolar	1.2	3.3	3.4	0.074	0.37	4835710-1

### Dynamic performances

#### 2P4233B10

Driver: Internal circuit  
Power supply: — 36V — 24V  
Current: 1A/phase bipolar  
Excitation mode: Full-step  
Load inertia JL = 0.94x10<sup>-4</sup>kg.m<sup>2</sup> (rubber coupling)

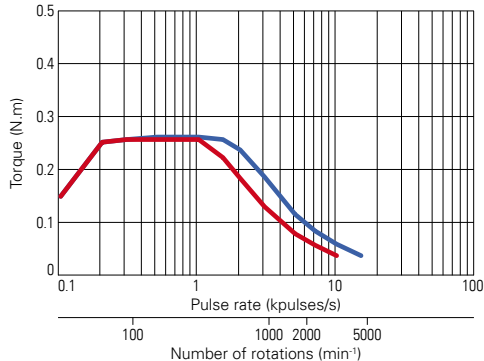

#### 2H4233B05

Driver: Internal circuit  
Power supply: — 36V — 24V  
Current: 0.48A/phase bipolar  
Excitation mode: Full-step  
Load inertia JL = 0.94x10<sup>-4</sup>kg.m<sup>2</sup> (rubber coupling)

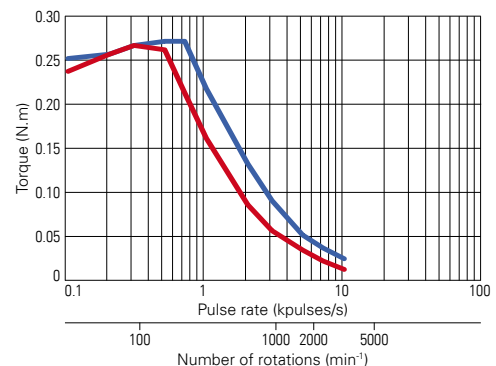

#### 2H4238B17

Driver: BS1D200P10  
Power supply: — 36VDC — 24VDC  
Current: 1.7A/phase bipolar  
Excitation mode: Full-step  
Load inertia JL = 0.94x10<sup>-4</sup>kg.m<sup>2</sup> (rubber coupling)

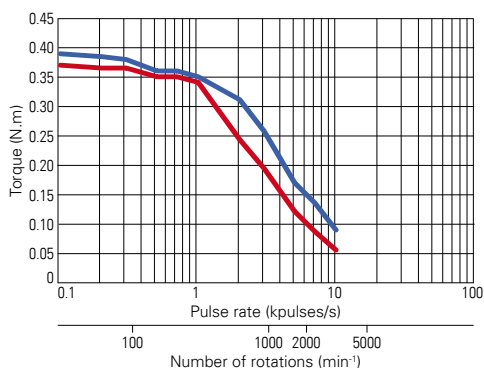

#### 2H4241B05

Driver: Internal circuit  
Power supply: — 36V — 24V  
Current: 0.5A/phase bipolar  
Excitation mode: Full-step  
Load inertia JL = 0.94x10<sup>-4</sup>kg.m<sup>2</sup> (rubber coupling)

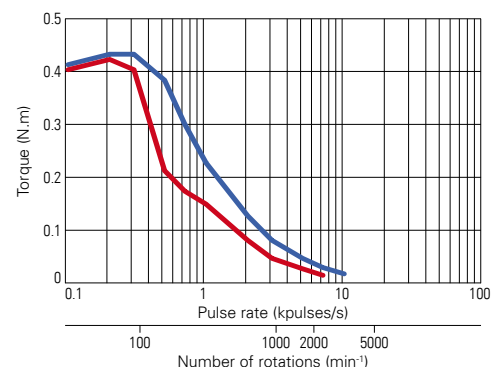

### 2H4241U12

Driver: US1D200P10  
 Power supply: — 36V — 24V  
 Current: 1.2A/phase unipolar  
 Excitation mode: Full-step  
 Load inertia JL = 0.94x10<sup>-4</sup>kg.m<sup>2</sup> (rubber coupling)

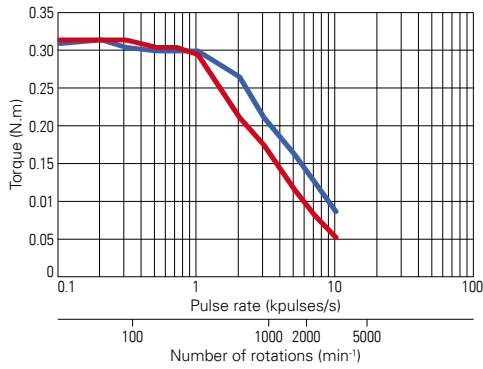

### 2H4248U12

Driver: US1D200P10  
 Power supply: — 36V — 24V  
 Current: 1.2A/phase unipolar  
 Excitation mode: Full-step  
 Load inertia JL = 0.94x10<sup>-4</sup>kg.m<sup>2</sup> (rubber coupling)

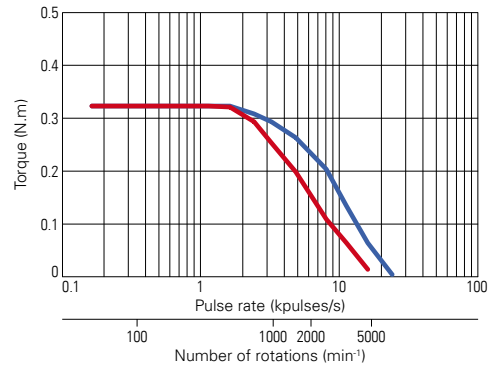

## Dimensions [Unit: mm]

2P4233B10Sx40  
 2P4233B10Mx1x

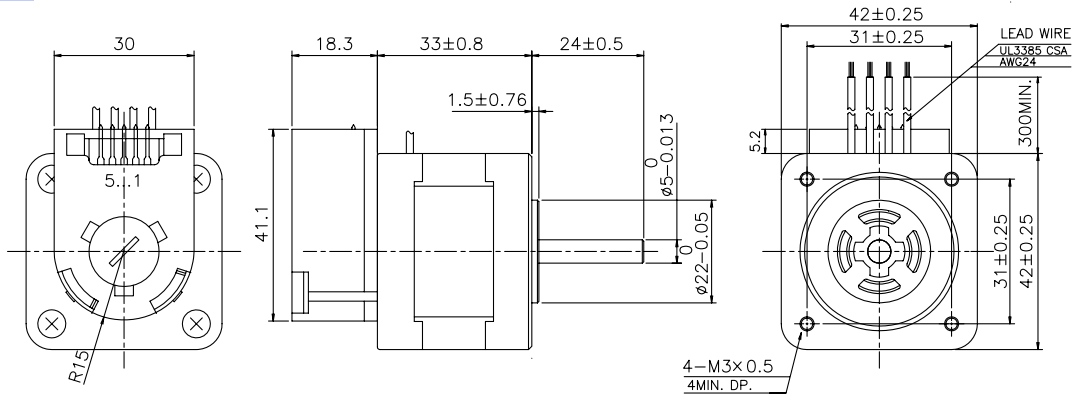

2H42xxxxR220

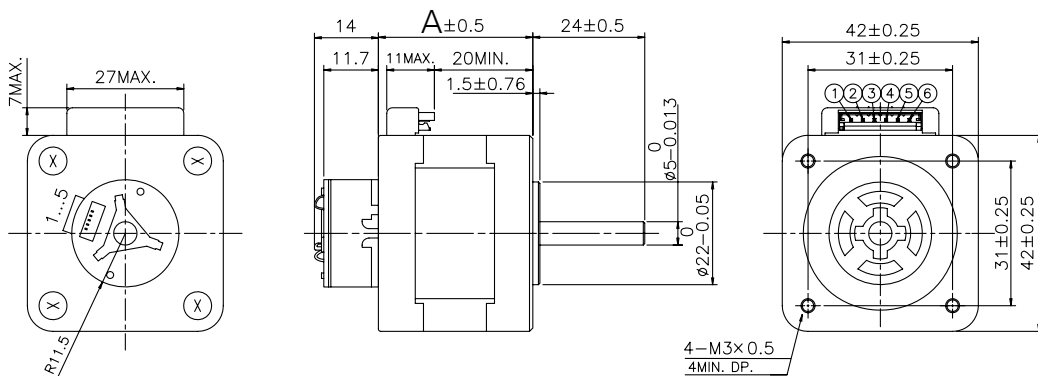

Motor Length	A [mm]
2H4233	33
2H4238	39
2H4248	48

35mm sq.

42mm sq.

56mm sq.

60mm sq.

86mm sq.

Encoder Specifications

Customization Service

**2H42xxxxSx40**  
**2H42xxxxMx1x**

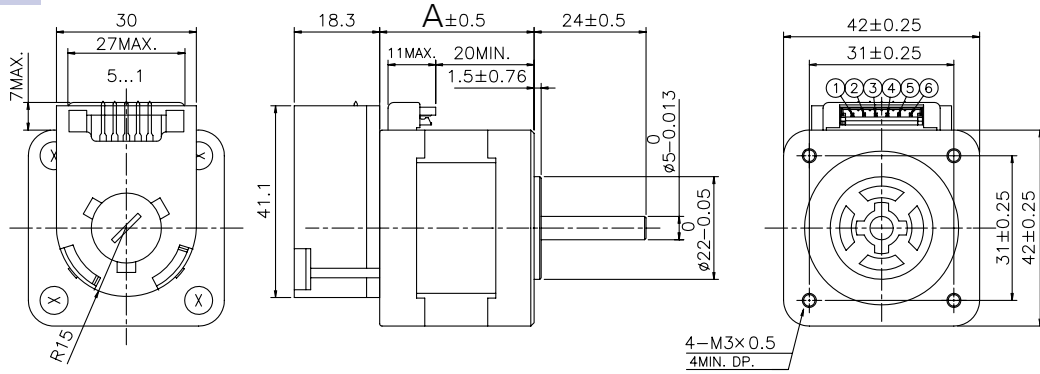

Motor Length	A [mm]
2H4233	33
2H4238	39
2H4241	41
2H4248	48

**Internal wiring**

( ) connector pin number

Unipolar winding

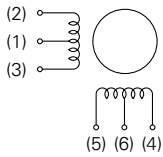

Bipolar winding

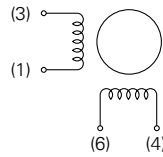

General Specification ▶ p. 26

Rotation Direction ▶ p. 27

**Motor cables**

Unipolar winding, Cable P/N: 4835710-1

Manufacturer: J.S.T. Mfg. Co., Ltd.  
 Housing: EHR-6 Black  
 Pin: SEH-001TP0.6

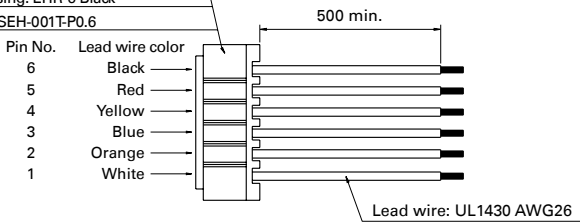

Bipolar winding, Cable P/N: 4835728-1

Manufacturer: J.S.T. Mfg. Co., Ltd.  
 Housing: EHR-6 Black  
 Pin: SEH-001TP0.6

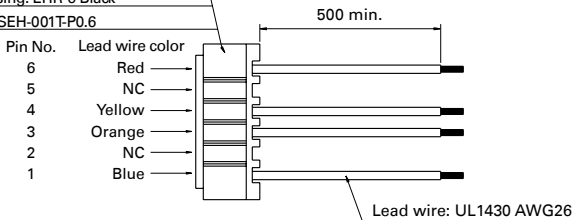

**Encoder cables**

R220 Encoder, Cable P/N: CRP12500

Manufacturer: MOLEX  
 Housing: 51021-0500  
 Terminal: 50079-8000 or 8100

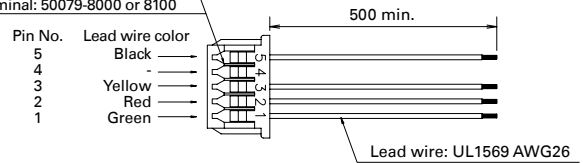

Sxxx, Mxxx Encoder, Cable P/N: CS3500

Manufacturer: MOLEX  
 Housing: 22-01-2055  
 or 22-01-3057

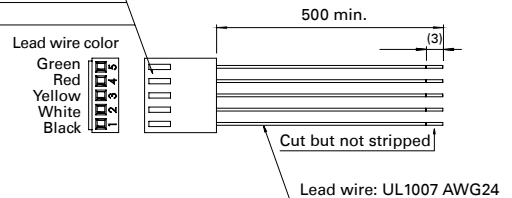

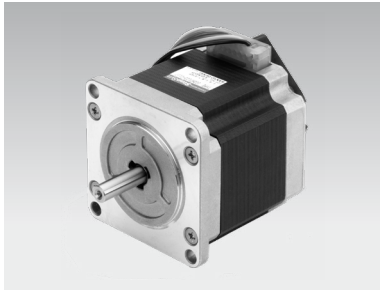

# 56 mm sq.

1.8° /step RoHS

Unipolar and Bipolar winding  
Lead wire type

Based motor	Holding torque at 2-phase energization [N.m min.]	Step angle °	Winding type	Rated current	Wiring resistance	Winding inductance	Rotor Inertia	Weight kg	Optional motor cable
				A/phase	Ω /phase	mH/phase	[x 10 <sup>-4</sup> kg.m <sup>2</sup> ]		
<b>2H5654U10</b>	0.83	1.8	Unipolar	1	6.7	15	0.21	0.65	-
<b>2H5654U20</b>	0.83	1.8	Unipolar	2	1.6	3.8	0.21	0.65	-
<b>2H5654B20</b>	0.83	1.8	Bipolar	2	0.8	3.8	0.21	0.65	-
<b>2H5676B20</b>	1.27	1.8	Bipolar	2	1.05	4.5	0.36	0.98	-
<b>2H5695B20</b>	2	1.8	Bipolar	2	2.3	10.4	0.49	1.3	-

## Dynamic performances

### 2H5654U10

Driver: Internal circuit  
Power supply: — 36V — 24V  
Current: 1A/phase unipolar  
Excitation mode: Full-step  
Load inertia JL = 2.6x10<sup>-4</sup>kg.m<sup>2</sup> (rubber coupling)

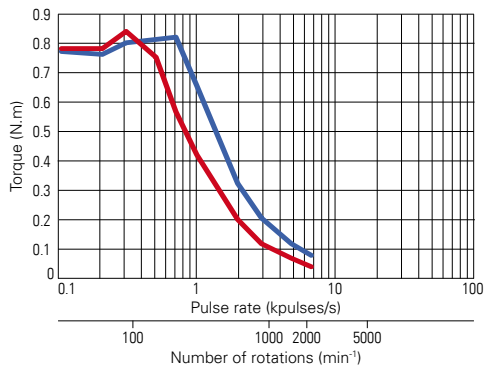

### 2H5654U20

Driver: US1D200P10  
Power supply: — 36V — 24V  
Current: 2A/phase bipolar  
Excitation mode: Full-step  
Load inertia JL = 0.94x10<sup>-4</sup>kg.m<sup>2</sup> (rubber coupling)

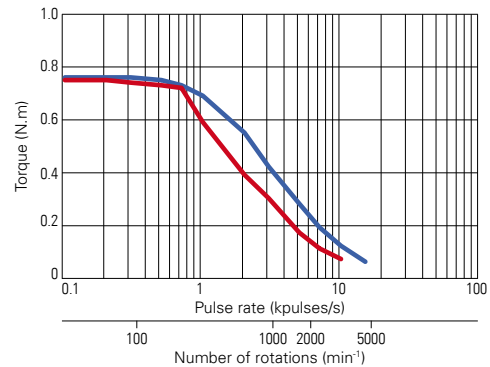

### 2H5654B20

Driver: BS1D200P10  
Power supply: — 36VDC — 24VDC  
Current: 2A/phase bipolar  
Excitation mode: Full-step  
Load inertia JL = 2.6x10<sup>-4</sup>kg.m<sup>2</sup> (rubber coupling)

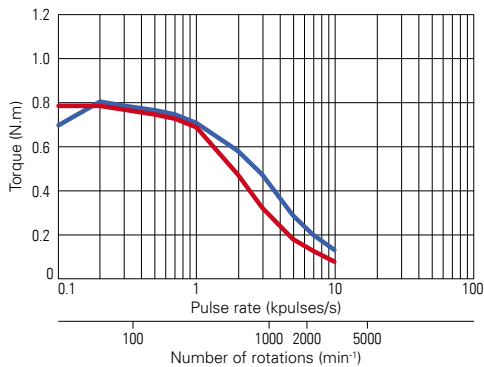

### 2H5676B20

Driver: BS1D200P10  
Power supply: — 36VDC — 24VDC  
Current: 2A/phase bipolar  
Excitation mode: Full-step  
Load inertia JL = 2.6x10<sup>-4</sup>kg.m<sup>2</sup> (rubber coupling)

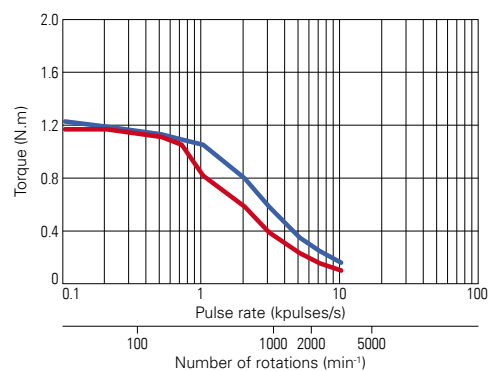

35mm sq.

42mm sq.

56mm sq.

60mm sq.

86mm sq.

Encoder Specifications

Customization Service

## 2H5695B20

Driver: Internal circuit  
 Power supply: — 36V — 24V  
 Current: 2A/phase bipolar  
 Excitation mode: Full-step  
 Load inertia  $J_L = 7.4 \times 10^{-4} \text{ kg.m}^2$  (rubber coupling)

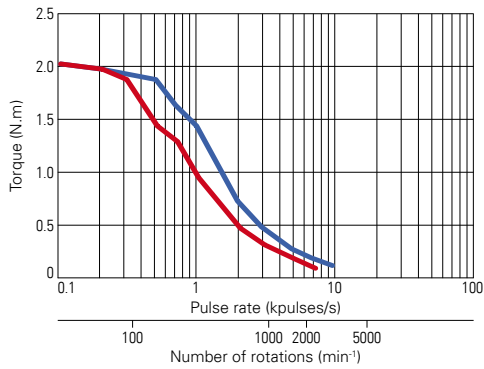

## Dimensions [Unit: mm]

### 2H5654xxxR220

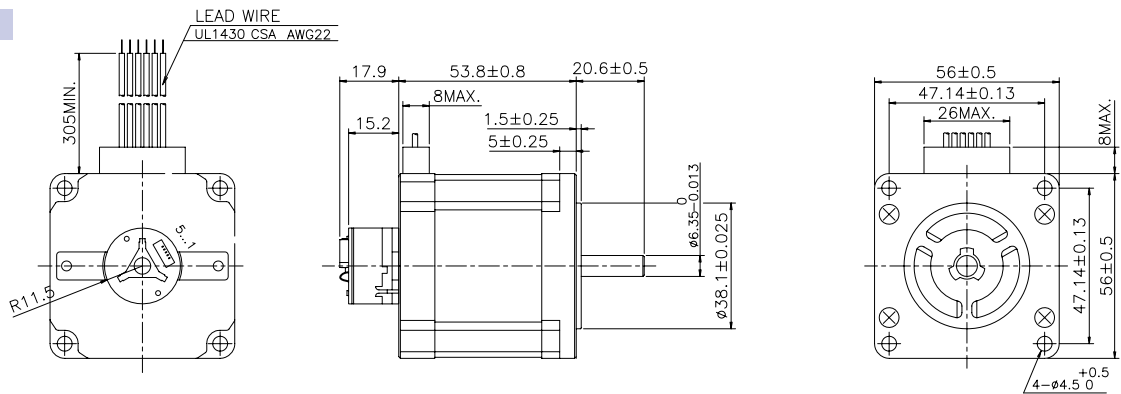

### 2H5695B20R220

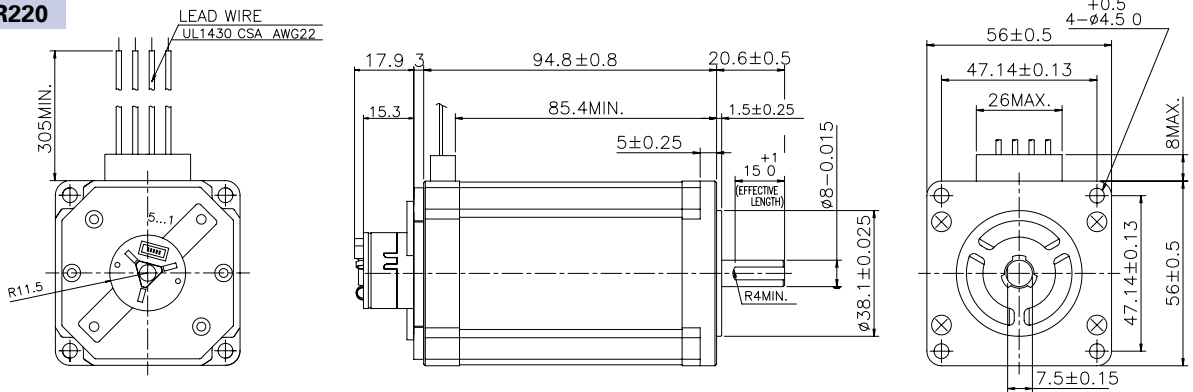

### 2H56xxxxSx40 2H56xxxxM21x

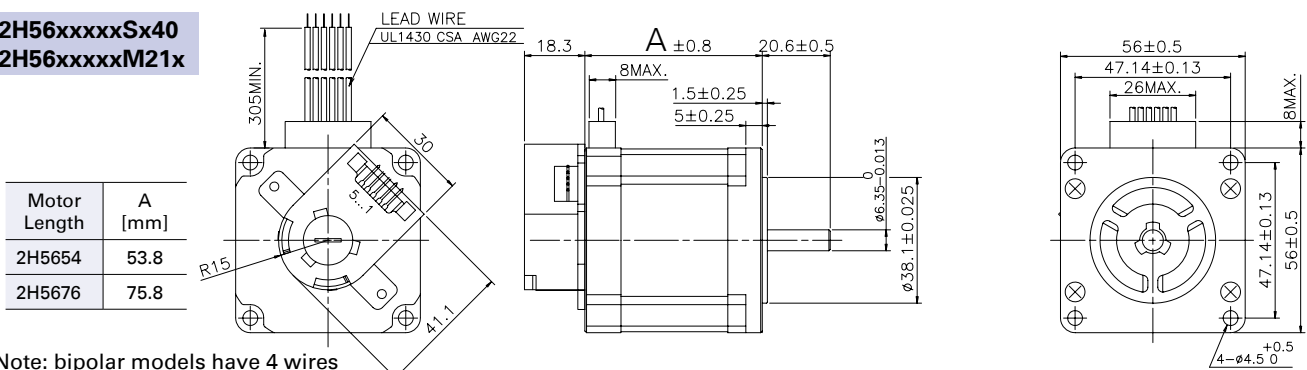

Note: bipolar models have 4 wires



**2H5695B20Sx40**  
**2H5695B20M21x**

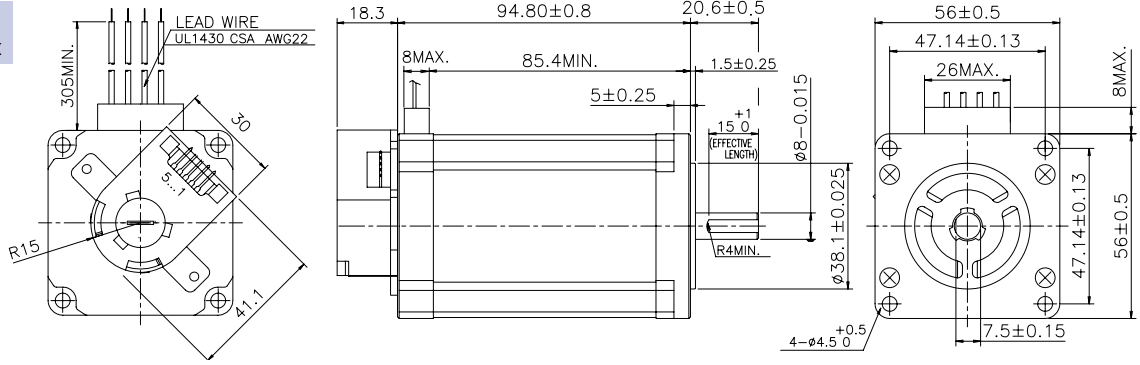

**2H56xxxxxL240**

Motor Length	A [mm]
2H5654	53.8
2H5676	75.8

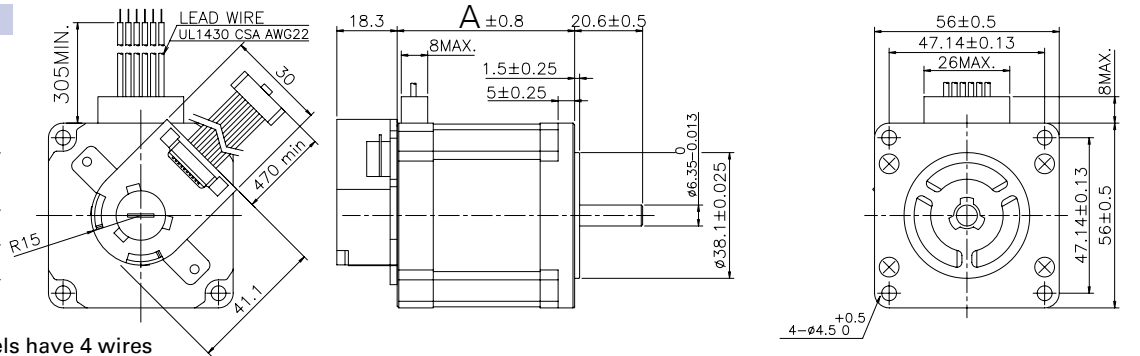

Note: bipolar models have 4 wires

**2H5695B20L240**

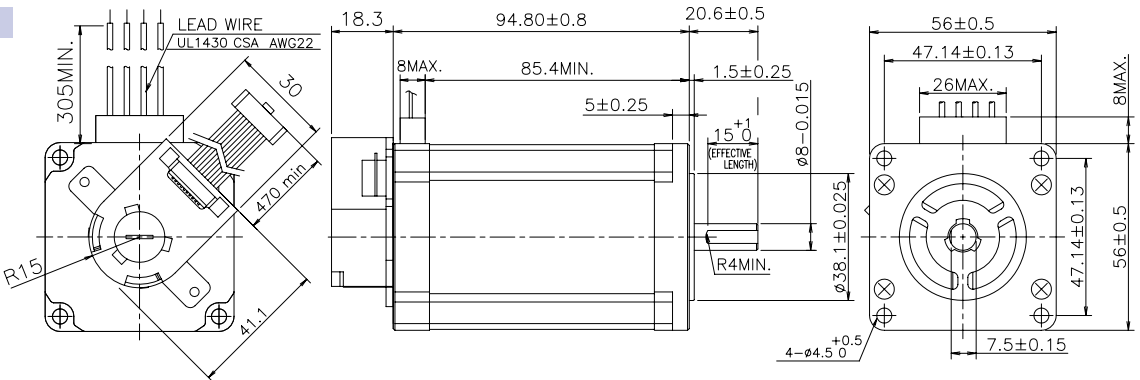

**Internal wiring**

Unipolar winding

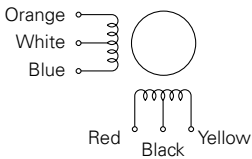

Bipolar winding

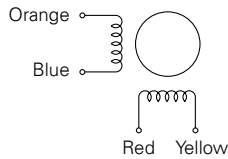

General Specification ▶ p. 26  
Rotation Direction ▶ p. 27

**Encoder cables**

R220 Encoder, Cable P/N: CRS22500

Manufacturer: MOLEX  
Housing: 51021-0500  
Terminal: 50079-8000 or 8100

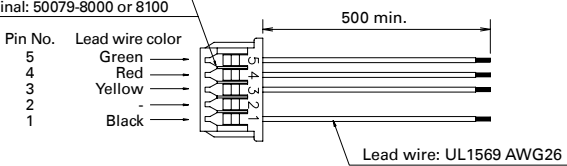

Sxxx, Mxxx Encoder, Cable P/N: CS3500

Manufacturer: MOLEX  
Housing: 22-01-2055  
or 22-01-3057

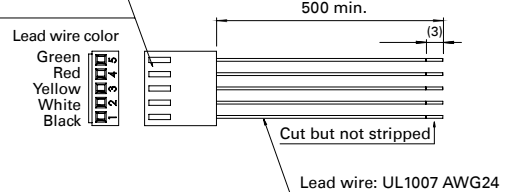

35mm sq.

42mm sq.

56mm sq.

60mm sq.

86mm sq.

Encoder Specifications

Customization Service

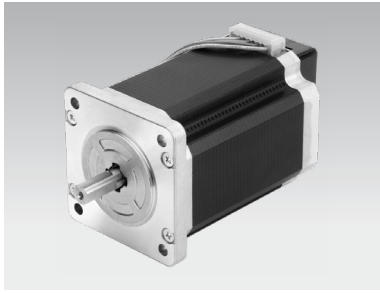

# 60 mm sq.

1.8° /step RoHS

Bipolar winding  
Lead wire type

Based motor	Holding torque at 2-phase energization [N.m min.]	Step angle °	Winding type	Rated current	Wiring resistance	Winding inductance	Rotor Inertia	Weight	Optional motor cable
				A/phase	Ω /phase	mH/phase	[x 10 <sup>-4</sup> kg.m <sup>2</sup> ]	kg	
<b>2H6043B20</b>	0.88	1.8	Bipolar	2	1.27	3.3	0.275	0.6	-
<b>2H6052B20</b>	1.37	1.8	Bipolar	2	1.55	5.5	0.4	0.77	-
<b>2H6084B20</b>	2.7	1.8	Bipolar	2	2.4	9.5	0.84	1.34	-

## Dynamic performances

### 2H6043B20

Driver: BS1D200P10  
Power supply: — 36V — 24V  
Current: 2A/phase bipolar  
Excitation mode: Full-step  
Load inertia JL = 7.4x10<sup>-4</sup>kg.m<sup>2</sup> (rubber coupling)

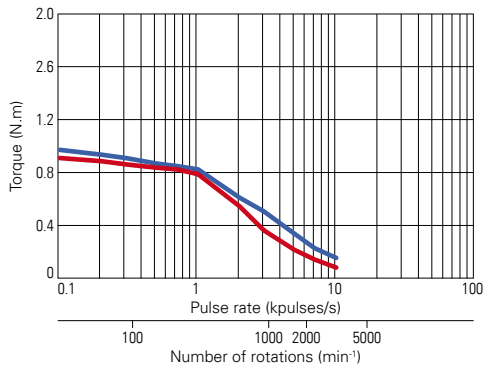

### 2H6052B20

Driver: BS1D200P10  
Power supply: — 36V — 24V  
Current: 2A/phase bipolar  
Excitation mode: Full-step  
Load inertia JL = 7.4x10<sup>-4</sup>kg.m<sup>2</sup> (rubber coupling)

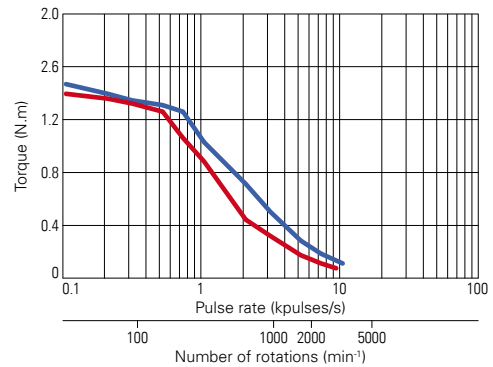

### 2H6084B20

Driver: BS1D200P10  
Power supply: — 36V — 24V  
Current: 2A/phase bipolar  
Excitation mode: Full-step  
Load inertia JL = 7.4x10<sup>-4</sup>kg.m<sup>2</sup> (rubber coupling)

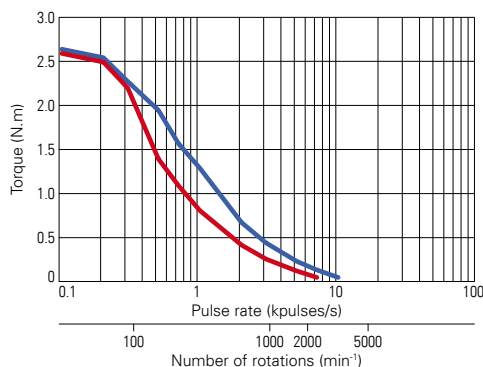

## Dimensions [Unit: mm]

### 2H60xxB20R220

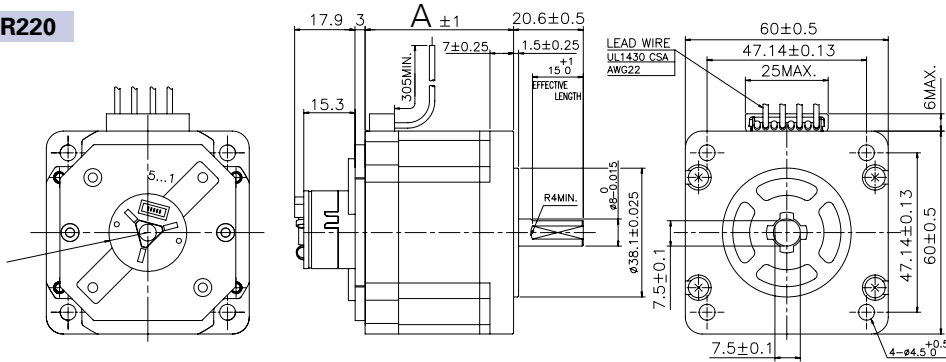

Motor Length	A [mm]
2H6043	43.5
2H6052	52.5
2H6084	84.5

### 2H60xxB20Sx40 2H60xxB20M21x

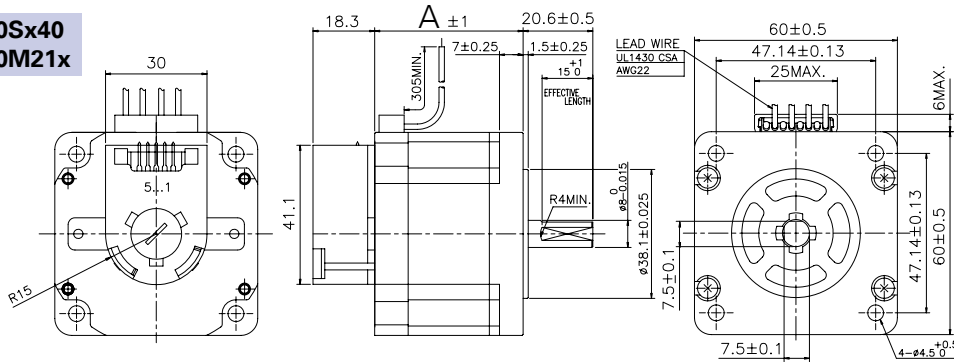

Motor Length	A [mm]
2H6043	43.5
2H6052	52.5
2H6084	84.5

### 2H60xxB20L240

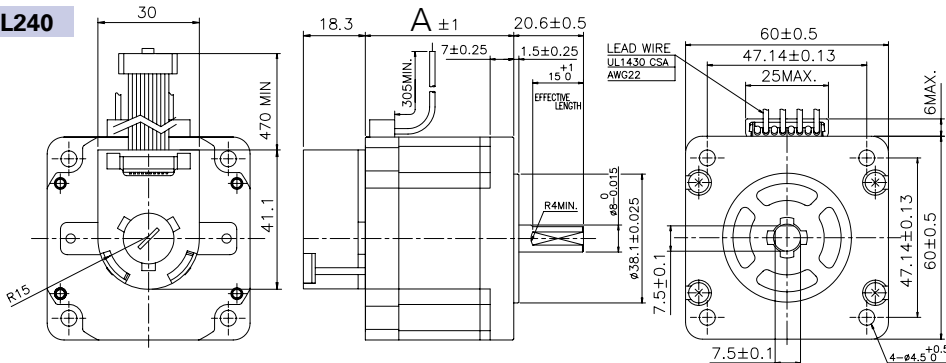

Motor Length	A [mm]
2H6043	43.5
2H6052	52.5
2H6084	84.5

## Internal wiring

Bipolar winding

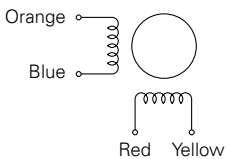

General Specification ▶ p. 26  
Rotation Direction ▶ p. 27

## Encoder cables

R220 Encoder, Cable P/N: CRS22500

Manufacturer: MOLEX

Housing: 51021-0500

Terminal: 50079-8000 or 8100

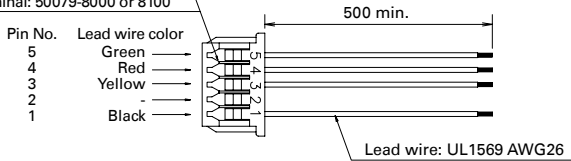

Sxxx, Mxxx Encoder, Cable P/N: CS3500

Manufacturer: MOLEX

Housing: 22-01-2055

or 22-01-3057

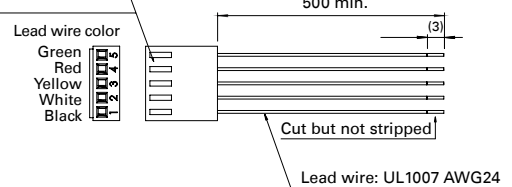

35mm sq.

42mm sq.

56mm sq.

60mm sq.

86mm sq.

Encoder Specifications

Customization Service



# 86 mm sq.

1.8° /step RoHS

Bipolar winding  
Lead wire type

Based motor	Holding torque at 2-phase energization	Step angle °	Winding type	Rated current A/phase	Wiring resistance Ω /phase	Winding inductance mH/phase	Rotor Inertia [x 10 <sup>-4</sup> kg.m <sup>2</sup> ]	Weight kg	Optional motor cable
	[N.m min.]								
<b>2H8666B60</b>	3.3	1.8	Bipolar	6	0.29	1.7	1.48	1.75	-
<b>2H8696B60</b>	6.4	1.8	Bipolar	6	0.36	2.8	3	2.9	-
<b>2H86127B60</b>	9.0	1.8	Bipolar	6	0.46	3.8	4.5	4.0	-

## Dynamic performances

### 2H8666B60

Driver: Internal circuit  
Power supply: 100VAC  
Current: 6A/phase bipolar  
Excitation mode: Full-step  
Load inertia JL = 15.3x10<sup>-4</sup>kg.m<sup>2</sup> (rubber coupling)

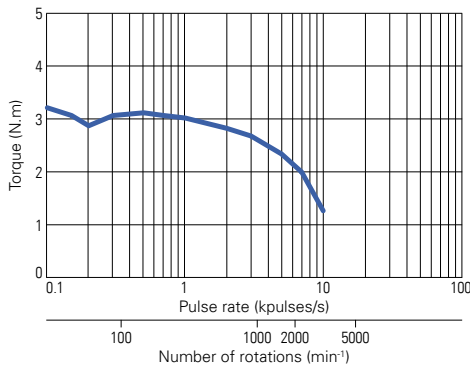

### 2H8696B60

Driver: Internal circuit  
Power supply: 100VAC  
Current: 6A/phase bipolar  
Excitation mode: Full-step  
Load inertia JL = 15.3x10<sup>-4</sup>kg.m<sup>2</sup> (rubber coupling)

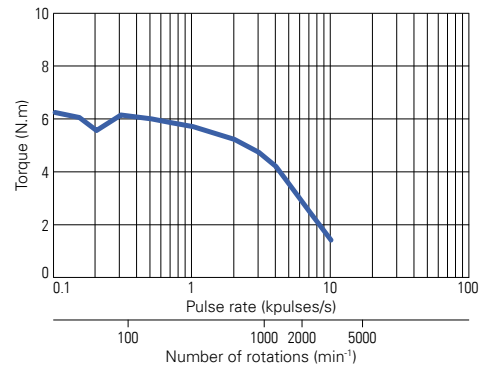

### 2H86127B60

Driver: Internal circuit  
Power supply: 100VAC  
Current: 6A/phase bipolar  
Excitation mode: Full-step  
Load inertia JL = 44x10<sup>-4</sup>Kg.m<sup>2</sup> (rubber coupling)

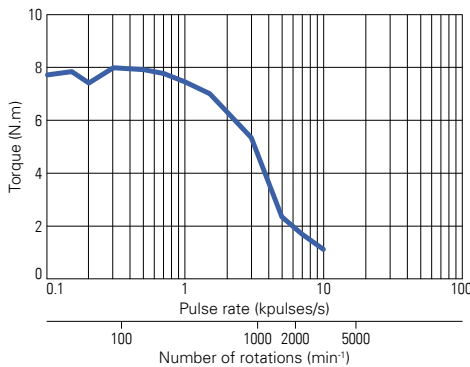

## Dimensions [Unit: mm]

### 2H86xxB60R220 2H86xxxB60R220

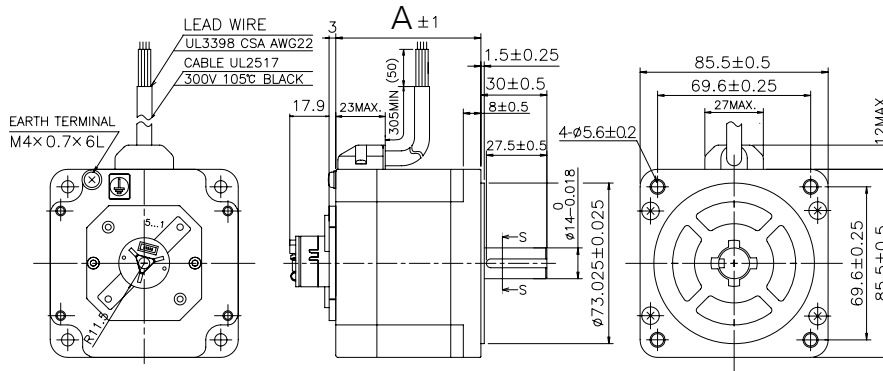

Motor Length	A [mm]
2H8666	66
2H8696	96.5
2H86127	127

### 2H86xxB60Sx40 2H86xxxB60Sx40

### 2H86xxB60M21x 2H86xxxB60M21x

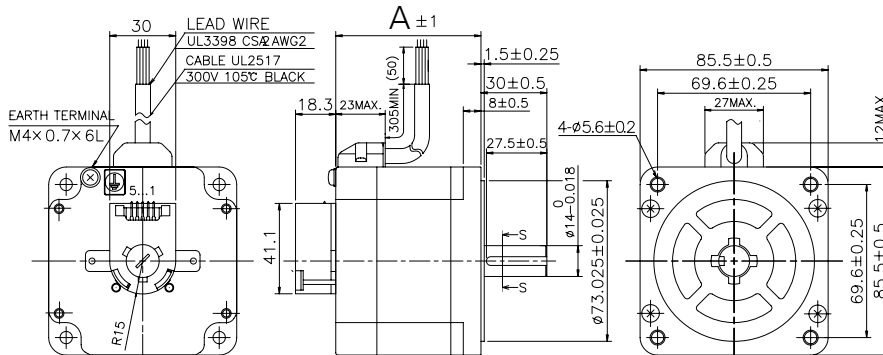

Motor Length	A [mm]
2H8666	66
2H8696	96.5
2H86127	127

### 2H86xxB60L240 2H86xxxB60L240

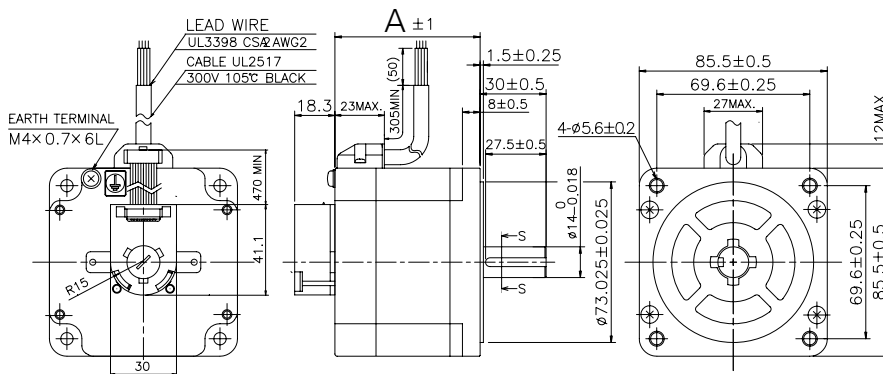

Motor Length	A [mm]
2H8666	66
2H8696	96.5
2H86127	127

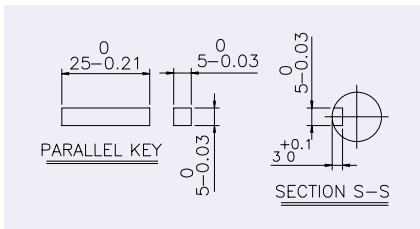

## Internal wiring

### Bipolar winding

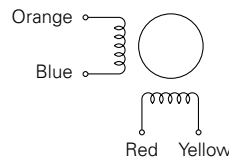

General Specification ▶ p. 26  
Rotation Direction ▶ p. 27

## Encoder cables

### R220 Encoder, Cable P/N: CRS22500

Manufacturer: MOLEX  
Housing: 51021-0500  
Terminal: 50079-8000 or 8100

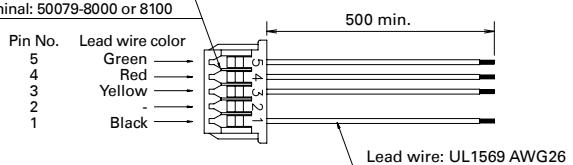

### Sxxx, Mxxx Encoder, Cable P/N: CS3500

Manufacturer: MOLEX  
Housing: 22-01-2055  
or 22-01-3057

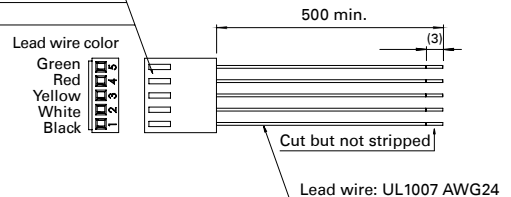

35mm sq.

42mm sq.

56mm sq.

60mm sq.

86mm sq.

Encoder Specifications

Customization Service



# R type Encoder

RoHS

- Two channel quadrature outputs
- Resolution 200 counts per revolution
- TTL compatible
- Single 5VDC supply
- HEDR serie encoders from Broadcom Limited

## Encoder features

Parameter	R220
Supply voltage [VDC]	5 ± 0.5
Max. Supply current [mA]	33
Output voltage [VDC]	VOH = 2.4 min, VOL = 0.4 max
Output channels	2 (A, B)
Maximum frequency [kHz]	16

## Encoder pin-outs

Pins	R220	R220
	35, 42mm sq.	56, 60, 86mm sq.
Pin 1	Channel B	GND
Pin 2	5 VDC	NC
Pin 3	Channel A	Channel A
Pin 4	NC	5 VDC
Pin 5	GND	Channel B

## Encoder P/N

R220: 2 channels, 200CPR

## Output waveforms

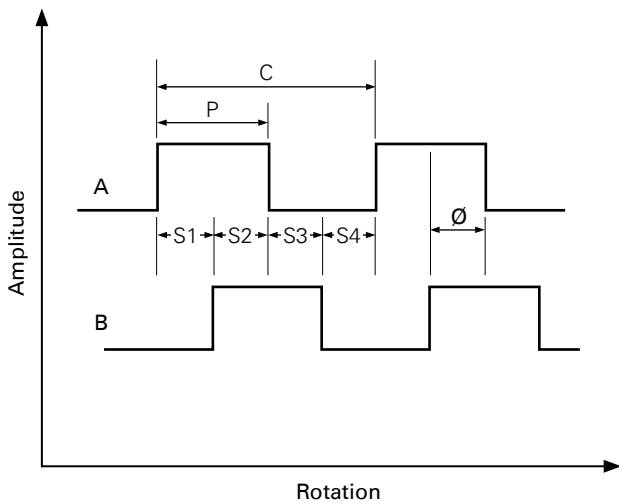

## Encoding characteristics

Parameter	Symbol	R220	
		Typ.*	Max.
Pulse width error [°e]	$\Delta P$	7	75
Logic width error [°e]	$\Delta S$	15	60
Phase error [°e]	$\Delta \emptyset$	15	60
Position error [arcmin.]	$\Delta \Theta$	50	120
Cycle error [°e]	$\Delta C$	10	45

\*Typical values specified at supply voltage = 5.0 V and 25°C

## Electrical interface

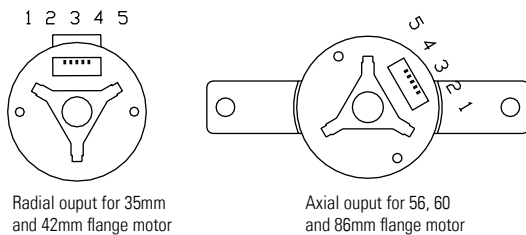

Pull-up resistors on output pins have already been integrated. Each of the three encoder outputs can drive a single TTL load in this configuration.

## Suitable connectors

Manufacturer	Part number	
	Housing	Contact
Molex	51021-0500	50079-8000

## Encoder cables

R220 Encoder, 35 & 42mm flange Motor, Cable P/N: CRP12500

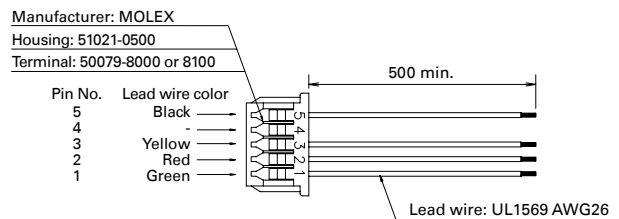

R220 Encoder, 56, 60 & 86mm flange Motor, Cable P/N: CRS22500

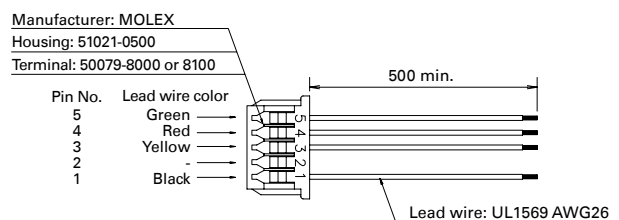



# S type Encoder

RoHS

- Two channel quadrature outputs with optional index pulse
- Resolution 400 or 500 counts per revolution
- Single ended output signals, TTL compatible
- Single 5VDC supply
- HEDS serie encoders from Broadcom Limited

## Encoder features

Parameter	S240	S340
Supply voltage [VDC]	5 ± 0.5	
Max. Supply current [mA]	40	85
Output voltage [VDC]	VOH = 2.4 min, VOL = 0.4 max	
Output channels	2 (A, B)	3 (A, B, I)
Maximum frequency [kHz]	100	

## Encoder pin-outs

Pins	S240	S340
Pin 1	GND	
Pin 2	NC	Channel I
Pin 3	Channel A	
Pin 4	5 VDC	
Pin 5	Channel B	

## Encoder P/N

**S240:** 2 channels, 400CPR  
**S340:** 3 channels, 400CPR

## Output waveforms

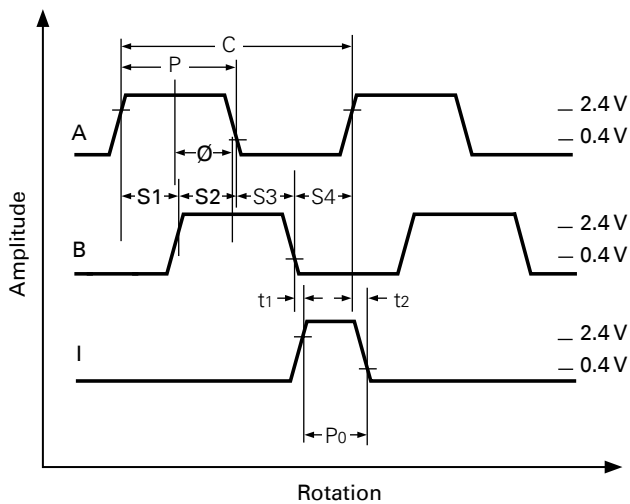

## Encoding characteristics

Parameter	Symbol	S240			S340		
		Min.	Typ.*	Max.	Min.	Typ.*	Max.
Pulse width error [°e]	$\Delta P$	7	45	5	45		
Logic width error [°e]	$\Delta S$	5	45	5	35		
Phase error [°e]	$\Delta \emptyset$	2	20	2	15		
Position error [arcmin.]	$\Delta \Theta$	10	40	10	40		
Cycle error [°e]	$\Delta C$	3	5.5	3	5.5		
Index pulse width [°e]	$P_0$			55	90	125	
CH.I rise after CH.A or CH.B fall [ns]	$t_1$			-300	100	250	
CH.I fall after CH.A or CH.B rise [ns]	$t_2$			70	150	1000	

\*Typical values specified at supply voltage = 5.0 VDC and 25°C

## Electrical interface

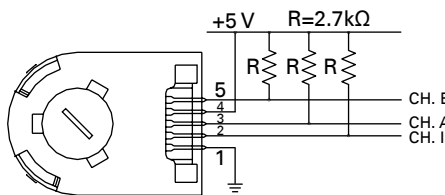

S340 encoders require 2.7kΩ (±10%) pull-up resistors on output pins 2,3 and 5 (Channels I, A and B). These pull-up resistors should be located as close to the encoder as possible.

S240 encoders do not normally require pull-up resistors. However, 3.2kΩ pull-up resistors on output pins 3 and 5 (Channels A and B) are recommended.

## Suitable connectors

Manufacturer	Part number	
	Housing	Contact
AMP	103686-4	640442-5
Molex	2695 series	2759 series
FCI	65039-032	4825X-000

## Encoder cables

S240, S340 Encoder, Cable P/N: CS3500

Manufacturer: MOLEX  
 Housing: 22-01-2055  
 or 22-01-3057

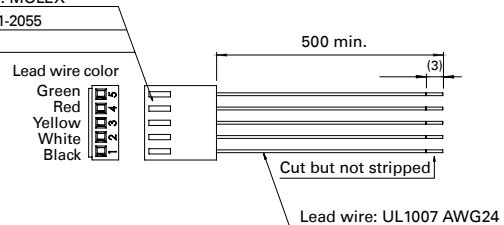

35mm sq.

42mm sq.

56mm sq.

60mm sq.

86mm sq.

Encoder Specifications

Customization Service



# M type Encoder RoHS

- Two channel quadrature outputs with optional index pulse
- Resolution 1000 or 1024 counts per revolution
- Single ended output signals, TTL compatible
- Single 5VDC supply
- HEDM serie encoders from Broadcom Limited

## Encoder features

Parameter	M21x	M310
Supply voltage [VDC]	5 ± 0.5	
Max. Supply current [mA]	85	
Output voltage [VDC]	VOH = 2.4 min, VOL = 0.4 max	
Output channels	2 (A, B)	3 (A, B, I)
Maximum frequency [kHz]	100	

## Encoder pin-outs

Pins	M21x	M310
Pin 1	GND	
Pin 2	NC	Channel I
Pin 3	Channel A	
Pin 4	5 VDC	
Pin 5	Channel B	

## Encoder P/N

**M210:** 2 channels, 1000CPR  
**M211:** 2 channels, 1024CPR  
**M310:** 3 channels, 1000CPR

## Output waveforms

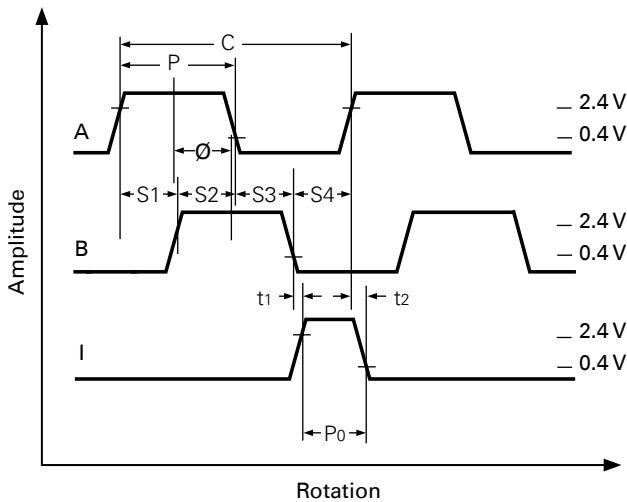

## Encoding characteristics

Parameter	Symbol	M21x			M310		
		Min.	Typ.*	Max.	Min.	Typ.*	Max.
Pulse width error [°e]	$\Delta P$		10	45	5	45	
Logic width error [°e]	$\Delta S$		10	45	5	35	
Phase error [°e]	$\Delta \emptyset$		2	15	2	15	
Position error [arcmin.]	$\Delta \Theta$		10	40	10	40	
Cycle error [°e]	$\Delta C$		3	7.5	6	12	
Index pulse width [°e]	$P_0$				50	90	130
CH.I rise after CH.A or CH.B fall [ns]	$t_1$				200	1000	1500
CH.I fall after CH.A or CH.B rise [ns]	$t_2$				0	300	1500

\*Typical values specified at supply voltage = 5.0 VDC and 25°C

## Electrical interface

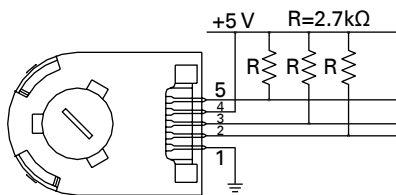

M310 encoder requires 2.7kΩ (±10%) pull-up resistors on output pins 2,3 and 5 (Channels I, A and B). These pull-up resistors should be located as close to the encoder as possible.

M21x encoders do not normally require pull-up resistors. However, 3.2kΩ pull-up resistors on output pins 3 and 5 (Channels A and B) are recommended.

## Encoder cables

M21x, M310 Encoder, Cable P/N: CS3500

Manufacturer: MOLEX  
 Housing: 22-01-2055  
 or 22-01-3057

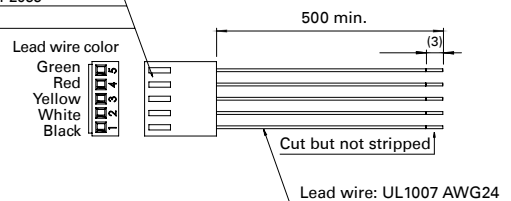

## Suitable connectors

Manufacturer	Part number	
	Housing	Contact
AMP	103686-4	640442-5
Molex	2695 series	2759 series
FCI	65039-032	4825X-000





# L type Encoder

RoHS

- Two channel quadrature complementary outputs
- Resolution 400 counts per revolution
- Industry standard Line Driver IC
- Single 5VDC supply
- HEDL serie encoders from Broadcom Limited

## Encoder features

Parameter	L240
Supply voltage [VDC]	5 ± 0.5
Max. Supply current [mA]	40
Output voltage [VDC]	VOH = 2.4 min, VOL = 0.4 max
Output channels	2 (A, B)
Maximum frequency [kHz]	100
Line driver IC *	AM26C31Q

\* Suggested line receivers are 26LS32 and 26LS33

## Encoder P/N

L240: 2 channels, 400CPR

## Output waveforms

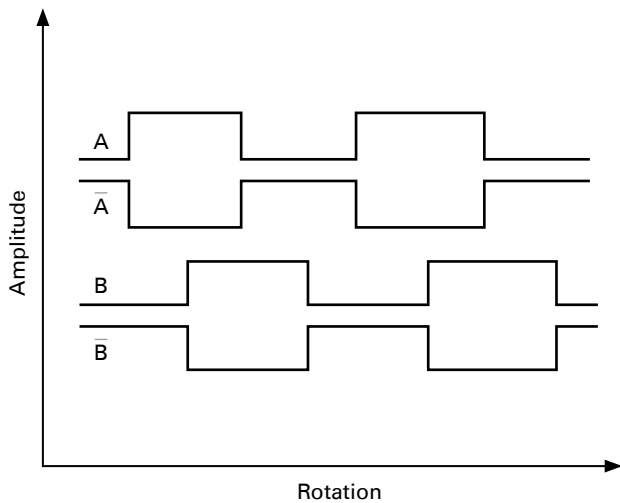

For additional information, please refer to S240 specifications.

## Encoder pin-outs

Pins		L240	
Pin 1	NC	Pin 6	A
Pin 2	5VDC	Pin 7	/B
Pin 3	GND	Pin 8	B
Pin 4	NC	Pin 9	NC
Pin 5	/A	Pin 10	NC

10 Position connector center polarized BERG HE10

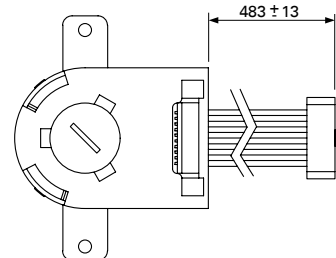
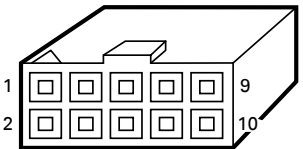

35mm sq.

42mm sq.

56mm sq.

60mm sq.

86mm sq.

Encoder Specifications

Customization Service

# General Specifications

Model number	2H35 □	2F42 □	2H42 □	2P42 □	2H56 □	2H60 □	2H86 □
Type	-						S1 (continuous operation)
Operating ambient temperature	-10°C to +50°C						-10°C to +40°C
Storage temperature	-20°C to +65°C						-20°C to +60°C
Operating ambient humidity	20 to 90% RH (no condensation)						95% max: 40°C max 57% max: 50°C max 35% max: 60°C max (no condensation)
Storage humidity	5 to 95% RH (no condensation)						
Operation altitude	1000 m max. above sea level						
Vibration resistance	Vibration frequency 10 to 500Hz, total amplitude 1.52 mm (10 to 70 Hz), vibration acceleration 150 m/s <sup>2</sup> (70 to 500 Hz), sweep time 15min/cycle, 12 sweeps in each X, Y and Z direction						
Impact resistance	500 m/s <sup>2</sup> of acceleration for 11 ms with half-sine wave applying three times for X, Y and Z axes each, 18 times in total						
Insulation class	Class B (+130°C)						Class F (+155°C)
Withstandable voltage	At normal temperature and humidity, no failure with 500 VAC @50/60 Hz applied for one minute between motor winding and frame			At normal temperature and humidity, no failure with 1000 VAC @50/60 Hz applied for one minute between motor winding and frame		At normal temperature and humidity, no failure with 1500 VAC @50/60 Hz applied for one minute between motor winding and frame	
Insulation resistance	At normal temperature and humidity, not less than 100 mΩ between winding and frame by 500 VDC megger						
Protection grade	-						IP43
Winding temperature rise	80 K max. (based on Sanyo Denki standard)						
Static angle error	± 0.09°			± 0.054°		± 0.09°	
Thrust play (1)	0.075 mm max. (load: 5 N)			0.075 mm max. (load: 10 N)			
Radial play (2)	0.025 mm max. (load: 5 N)						
Shaft run outs	0.025mm						
Concentricity of mounting pilot relative to shaft	∅ 0.075mm	∅ 0.05mm					∅ 0.075mm
Squareness of mounting surface relative to shaft	0.1mm			0.075mm		0.15mm	
Direction of motor mounting	Can be freely mounted vertically or horizontally						

1) Thrust play: shaft displacement under axial load

2) Radial play: shaft displacement under radial load applied 1/3rd of the length from the end of the shaft

# Internal Wiring and Rotation Direction

## Unipolar winding

Connector type \_\_\_\_\_

### Internal wire connection

( ) connector pin number, terminal block number

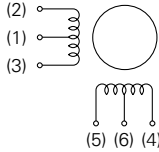

### Direction of motor rotation

When excited by a direct current in the order shown below, the direction of rotation is clockwise as viewed from the output shaft side.

		Connector pin number, terminal block number				
		(1.6)	(5)	(3)	(4)	(2)
Exciting order	1	+	-	-	-	-
	2	+	-	-	-	-
	3	+	-	-	-	-
	4	+	-	-	-	-

Lead wire type \_\_\_\_\_

### Internal wire connection

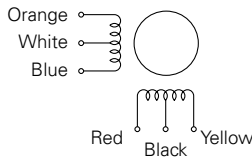

### Direction of motor rotation

When excited by a direct current in the order shown below, the direction of rotation is clockwise as viewed from the output shaft side.

		Lead wire color				
		White & black	Red	Blue	Yellow	Orange
Exciting order	1	+	-	-	-	-
	2	+	-	-	-	-
	3	+	-	-	-	-
	4	+	-	-	-	-

## Bipolar winding

Connector type model no.: 2F □ \_\_\_\_\_

### Internal wire connection

( ) connector pin number, terminal block number

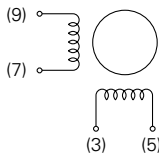

### Direction of motor rotation

When excited by a direct current in the order shown below, the direction of rotation is clockwise as viewed from the output shaft side.

		Connector pin number, terminal block number			
		(3)	(7)	(5)	(9)
Exciting order	1	-	-	+	+
	2	+	-	-	+
	3	+	+	-	-
	4	-	+	+	-

Connector type model no.: 2H □ \_\_\_\_\_

### Internal wire connection

( ) connector pin number, terminal block number

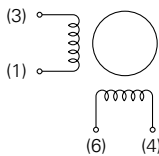

### Direction of motor rotation

When excited by a direct current in the order shown below, the direction of rotation is clockwise as viewed from the output shaft side.

		Connector pin number, terminal block number			
		(6)	(1)	(4)	(3)
Exciting order	1	-	-	+	+
	2	+	-	-	+
	3	+	+	-	-
	4	-	+	+	-

Lead wire type \_\_\_\_\_

### Internal wire connection

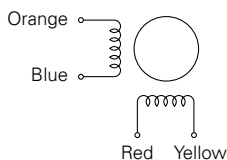

### Direction of motor rotation

When excited by a direct current in the order shown below, the direction of rotation is clockwise as viewed from the output shaft side.

		Lead wire color			
		Red	Blue	Yellow	Orange
Exciting order	1	-	-	+	+
	2	+	-	-	+
	3	+	+	-	-
	4	-	+	+	-

35mm sq.

42mm sq.

56mm sq.

60mm sq.

86mm sq.

Encoder Specifications

Customization Service



## Quick Customization Service

Have you ever struggled to meet a particular need using off-the-shelf stepping motor only to realize that you effectively have no solution space? If so, you have a valuable partner in SANYO DENKI EUROPE.

In addition to standard models of stepping motors with encoders, we specialize in designing and building custom solutions that meet the precise needs of our customers.

### Easy customization

With our extensive experience in designing and manufacturing custom stepping motors with encoder systems, our stepping motors can be easily customized to mount almost any types of encoders thanks to specific adaption plates.

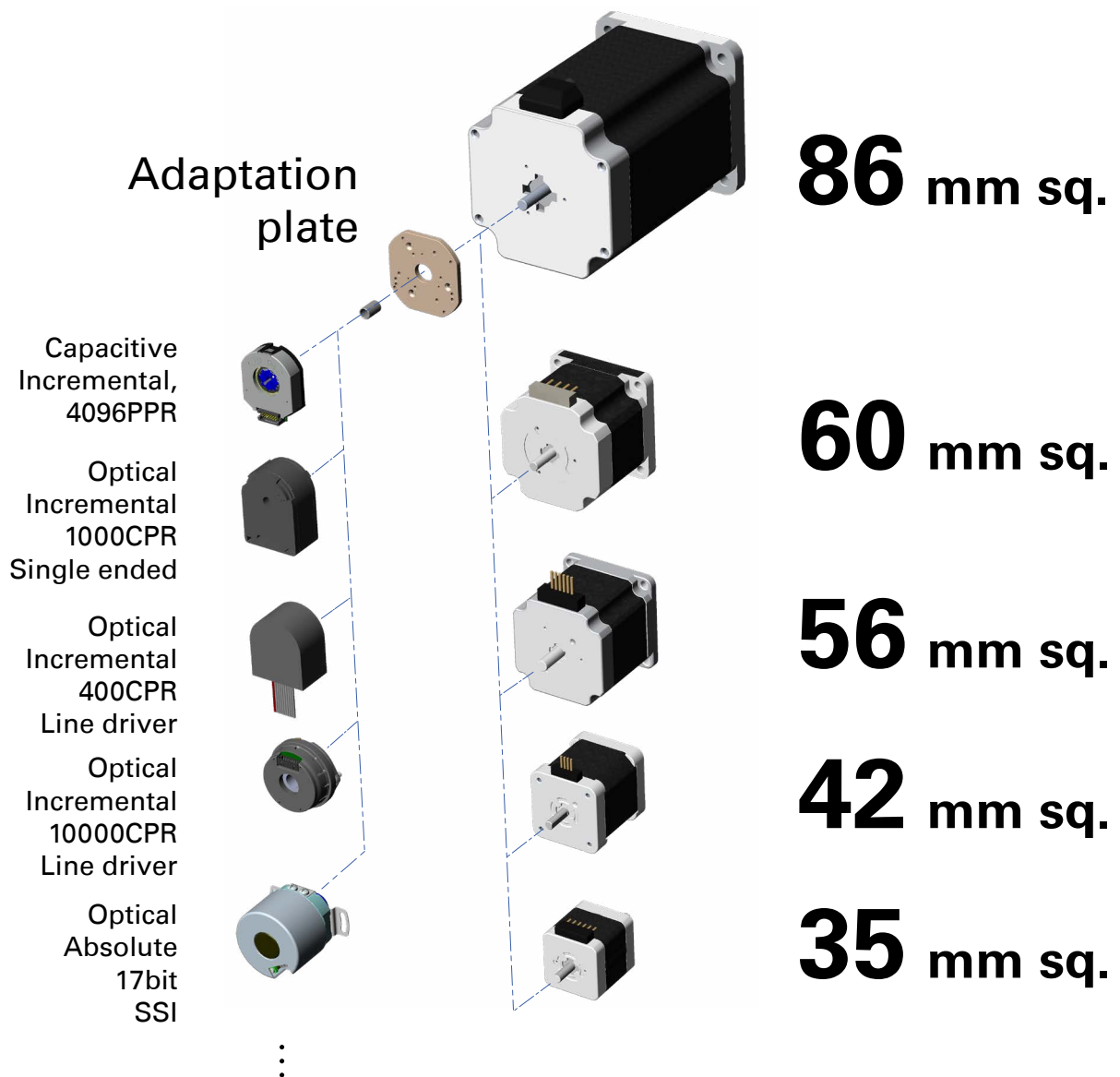

### Quick customization

With in-house CNC machining capabilities at Villepinte (FR) location, we are able to provide samples of customized stepping with encoders at a cost effective price with minimal lead times.

### Customization examples

#### 3D Printing Machine

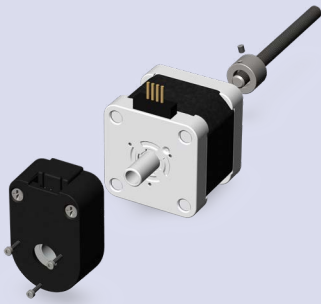

- 42mm sq. hollowshaft
- Non-captive leadscrew
- PTFE coating
- Anti-backlash nut
- Incremental hollowshaft encoder 400CPR

Easy integration and space saving  
PTFE coating for high efficiency and long life time

#### Medical Instrumentation

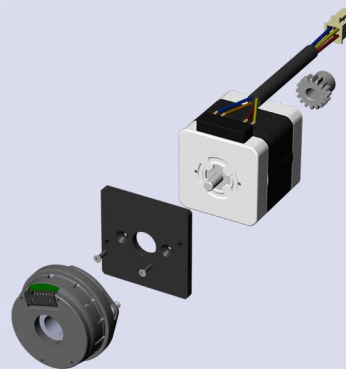

- 35mm sq.
- Pinion gears attached
- Customized harness
- Adaptation plate
- Incremental encoder 10.000CPR

Easy integration, quick sample delivery  
Complete solution  
High resolution encoder for accuracy and safety

#### Industrial Application

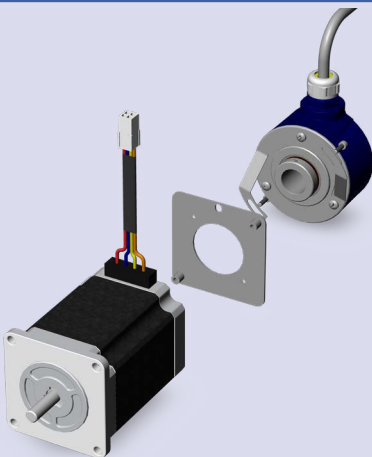

- 56mm sq.
- Customized harness
- Adaptation plate
- Ball bearing encoder
- 12 bit absolute encoder BiSS interface

Ball bearing encoder for robust design  
High resolution absolute encoder for accuracy  
High design flexibility: motors size, encoder protocols

#### Industrial Application

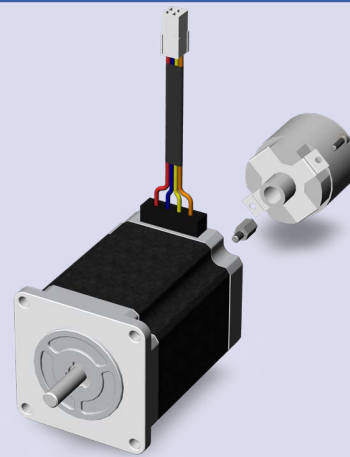

- 56mm sq.
- Customized harness
- Direct mounting
- Ball bearing encoder
- 12 bit absolute encoder SSI interface

Ball bearing encoder for robust design  
High resolution absolute encoder for accuracy  
High design flexibility: motors size, encoder protocols

## Inquiry Check Sheet

For more information regarding any products or services described here in, please contact our sales office listed on the back of this catalogue.

To SANYO DENKI EUROPE SA.

Date : \_\_\_\_\_

Company: \_\_\_\_\_

Department: \_\_\_\_\_

Name: \_\_\_\_\_

Tel: \_\_\_\_\_ Fax: \_\_\_\_\_

E-mail: \_\_\_\_\_

	Item	Contents	
1	Based motor P/N		
2	Encoder type	<input type="checkbox"/> Incremental	<input type="checkbox"/> Absolute single turn
3	Absolute turns	N/A	How many turns should be measured ? ( )
4	CPR Counts Per Revolution	( ) CPR	
5	Channels	<input type="checkbox"/> 2 (A / B) <input type="checkbox"/> Index pulse	N/A
6	Maximum speed	( ) rpm	
7	Maximum outer diameter	( ) mm	
8	Temperature range	( )°C to ( )°C	
9	Output type	<input type="checkbox"/> Open collector <input type="checkbox"/> Differential line driver <input type="checkbox"/> RS422 <input type="checkbox"/> Push / pull <input type="checkbox"/> Push / pull complementary <input type="checkbox"/> Others, please specify ( )	<input type="checkbox"/> SSI <input type="checkbox"/> BiSS <input type="checkbox"/> CANopen <input type="checkbox"/> EtherCAT <input type="checkbox"/> Others, please specify ( )
10	Encoder Connection	<input type="checkbox"/> Cable Cable length ( ) mm <input type="checkbox"/> Cable with connector Cable length ( ) mm Connector manufacturer ( ) Connector p/n ( ) <input type="checkbox"/> No specific option	
11	IP rating required	IP level ( )	
12	Safety standards	Please specify if any ( )	
15	Miscellaneous (information questions, etc.)		

# MEMO

---

## Notes before Purchase

The products in this catalog are designed to be used with general industrial devices.

Always follow the following precautions.

- Read the accompanying Instruction Manual carefully prior to using the product.
- If applying to medical devices and other equipment affecting people's lives, please contact us beforehand and take appropriate safety measures.
- If applying to equipment that can have significant effects on society and the general public, please contact us beforehand.
- Do not use this product in an environment where vibration is present, such as in a moving vehicle or shipping vessel.
- Do not perform any retrofitting, re-engineering, or modification to this equipment.
- The products presented in this catalog are meant to be used for general industrial applications. If using for special applications related to aviation and space, nuclear power, electric power, submarine repeaters, and the like, please contact us beforehand.

For any question or inquiry regarding the above, contact our Sales Department.

---

**SANYODENKI EUROPE S.A.**

11 rue Ferdinand de Lesseps, 95190 Goussainville, France

<https://www.sanyodenki.com/europe/en/>

TEL: + 33 1 48 63 26 61

The names of companies and/or their products specified in this catalog are the trade names, and/or trademarks and/or registered trademarks of such respective companies. Specifications are subject to change without notice.

CATALOG 23.0427